



NUREG-1635
Volume 11

Review and Evaluation of the Nuclear Regulatory Commission Safety Research Program

A Report to the U.S. Nuclear Regulatory Commission

Advisory Committee on Reactor Safeguards

AVAILABILITY OF REFERENCE MATERIALS IN NRC PUBLICATIONS

NRC Reference Material

As of November 1999, you may electronically access NUREG-series publications and other NRC records at NRC's Public Electronic Reading Room at <http://www.nrc.gov/reading-rm.html>. Publicly released records include, to name a few, NUREG-series publications; *Federal Register* notices; applicant, licensee, and vendor documents and correspondence; NRC correspondence and internal memoranda; bulletins and information notices; inspection and investigative reports; licensee event reports; and Commission papers and their attachments.

NRC publications in the NUREG series, NRC regulations, and Title 10, "Energy," in the *Code of Federal Regulations* may also be purchased from one of these two sources.

1. The Superintendent of Documents
U.S. Government Printing Office
Mail Stop SSOP
Washington, DC 20402-0001
Internet: bookstore.gpo.gov
Telephone: 202-512-1800
Fax: 202-512-2250
2. The National Technical Information Service
Springfield, VA 22161-0002
www.ntis.gov
1-800-553-6847 or, locally, 703-605-6000

A single copy of each NRC draft report for comment is available free, to the extent of supply, upon written request as follows:

Address: U.S. Nuclear Regulatory Commission
Office of Administration
Publications Branch
Washington, DC 20555-0001

E-mail: DISTRIBUTION.RESOURCE@NRC.GOV
Facsimile: 301-415-2289

Some publications in the NUREG series that are posted at NRC's Web site address <http://www.nrc.gov/reading-rm/doc-collections/nuregs> are updated periodically and may differ from the last printed version. Although references to material found on a Web site bear the date the material was accessed, the material available on the date cited may subsequently be removed from the site.

Non-NRC Reference Material

Documents available from public and special technical libraries include all open literature items, such as books, journal articles, transactions, *Federal Register* notices, Federal and State legislation, and congressional reports. Such documents as theses, dissertations, foreign reports and translations, and non-NRC conference proceedings may be purchased from their sponsoring organization.

Copies of industry codes and standards used in a substantive manner in the NRC regulatory process are maintained at—

The NRC Technical Library
Two White Flint North
11545 Rockville Pike
Rockville, MD 20852-2738

These standards are available in the library for reference use by the public. Codes and standards are usually copyrighted and may be purchased from the originating organization or, if they are American National Standards, from—

American National Standards Institute
11 West 42nd Street
New York, NY 10036-8002
www.ansi.org
212-642-4900

Legally binding regulatory requirements are stated only in laws; NRC regulations; licenses, including technical specifications; or orders, not in NUREG-series publications. The views expressed in contractor-prepared publications in this series are not necessarily those of the NRC.

The NUREG series comprises (1) technical and administrative reports and books prepared by the staff (NUREG-XXXX) or agency contractors (NUREG/CR-XXXX), (2) proceedings of conferences (NUREG/CP-XXXX), (3) reports resulting from international agreements (NUREG/IA-XXXX), (4) brochures (NUREG/BR-XXXX), and (5) compilations of legal decisions and orders of the Commission and Atomic and Safety Licensing Boards and of Directors' decisions under Section 2.206 of NRC's regulations (NUREG-0750).

DISCLAIMER: This report was prepared as an account of work sponsored by an agency of the U.S. Government. Neither the U.S. Government nor any agency thereof, nor any employee, makes any warranty, expressed or implied, or assumes any legal liability or responsibility for any third party's use, or the results of such use, of any information, apparatus, product, or process disclosed in this publication, or represents that its use by such third party would not infringe privately owned rights.

Review and Evaluation of the Nuclear Regulatory Commission Safety Research Program

A Report to the U.S. Nuclear Regulatory Commission

Manuscript Completed: June 2014
Date Published: December 2014

ABSTRACT

This report to the U.S. Nuclear Regulatory Commission (NRC) presents the observations and recommendations of the Advisory Committee on Reactor Safeguards (ACRS) concerning the NRC Safety Research Program being carried out by the Office of Nuclear Regulatory Research. In its evaluation of the NRC research activities, the ACRS considered the programmatic justification for the research, as well as the technical approaches and progress of the work. The evaluation identifies research crucial to the NRC mission.

TABLE OF CONTENTS

ABSTRACT.....	iii
FIGURES.....	vii
TABLES.....	vii
ABBREVIATIONS.....	xi
1. INTRODUCTION.....	1
2. GENERAL OBSERVATIONS AND RECOMMENDATIONS.....	3
3. FUKUSHIMA FORENSICS: UNDERSTANDING SEVERE ACCIDENT PROGRESSION.....	11
4. ADVANCED REACTOR DESIGNS.....	15
5. DIGITAL INSTRUMENTATION AND CONTROL SYSTEMS.....	19
6. FIRE SAFETY.....	23
7. REACTOR FUEL.....	31
8. HUMAN FACTORS AND HUMAN RELIABILITY.....	37
9. MATERIALS AND METALLURGY.....	41
10. NEUTRONICS AND CRITICALITY SAFETY.....	51
11. OPERATIONAL EXPERIENCE.....	55
12. PROBABILISTIC RISK ASSESSMENT.....	59
13. RADIATION PROTECTION.....	67
14. NUCLEAR MATERIALS AND WASTE.....	73
15. SEISMIC AND STRUCTURAL ENGINEERING.....	75
16. SEVERE ACCIDENTS AND SOURCE TERM.....	79
17. THERMAL HYDRAULICS.....	85
18. REFERENCES.....	91

FIGURES

1. Current NRC Research Activities in Fire Safety.....	29
2. Current NRC Research Activities in Reactor Fuel	35
3. Current NRC Research Activities in Human Factors and Human Reliability	40
4. Current NRC Research Activities in Materials and Metallurgy	49
5. Current NRC Research Activities in Operational Experience	58
6. Current NRC Research Activities in PRA	65
7. Current NRC Research Activities in Radiation Protection	71
8. Current NRC Research Activities Related to Severe Accident and Source Term	83
9. Current NRC Research Activities in Thermal-Hydraulics Research.....	90

TABLES

1. International Collaborative Severe Accident Experimental Research Programs with NRC Participation	84
--	----

ABBREVIATIONS

ABWR	advanced boiling-water reactor
ACRS	Advisory Committee on Reactor Safeguards
ADAMS	Agencywide Documents Access & Management System
AECL	Atomic Energy of Canada Limited
AEOD	Office for Analysis and Evaluation of Operational Data
AIChE	American Institute of Chemical Engineers
ALARA	as low as is reasonably achievable
AMPs	aging management programs
ANL	Argonne National Laboratory
ANS	American Nuclear Society
AOOs	anticipated operational occurrences
APWR	advanced pressurized-water reactor
ASME	American Society of Mechanical Engineers
ASP	Accident Sequence Precursor Program
ASTM	American Society for Testing and Materials
ATWS	anticipated transient without scram
BIP	Behavior of Iodine Project
BWR	boiling-water reactor
CAROLFIRE	cable response to live fire
CCF	common-cause failure
CFD	computational fluid dynamics
CFR	<i>Code of Federal Regulations</i>
CHRISTI-FIRE	cable heat release, ignition, and spread in tray installations during fire
CONOPS	concept of operations
CRDM	control rod drive mechanism
CSARP	Cooperative Severe Accident Research Program
DI&C	digital instrumentation and control
DOE	U.S. Department of Energy
EAC	environmentally assisted cracking
EDMGs	extensive damage management guidelines
EIS	environmental impact statement
EMUG	European MELCOR user group
EOPs	emergency operating procedures
EPAct	Energy Policy Act
EPIX	Equipment Performance and Information Exchange System
EPMDA	expanded proactive materials degradation assessment
EPR	evolutionary power reactor
EPRI	Electric Power Research Institute
ESBWR	economic simplified boiling water reactor
ESP	early site permit
FCI	fuel-coolant interaction
FMEA	failure modes and effects analysis
FSME	Office of Federal and State Materials and Environmental Management Programs
GDC	general design criteria
GSI	generic safety issue
GUI	graphical user interface

ABBREVIATIONS (Cont'd)

GWd/t	gigawatt-days per metric ton
HAMMLAB	Halden Man-Machine Laboratory
HDPE	high-density polyethylene
HERA	human event repository and analyses
HF	human factor
HFE	human factors engineering
HRA	Human Reliability Analysis
HRP	Halden Reactor Project
HSI	human system interface
HTGR	high-temperature gas-cooled reactor
I&C	instrumentation and control
IAEA	International Atomic Energy Agency
IASCC	irradiation assisted stress corrosion cracking
ICG-EAC	International Cooperative Group on Environmentally Assisted Cracking
ICRP	International Commission on Radiological Protection
ICSP	international collaborative standard problem
IDEAS	Integrated Decision-tree Human Event Analysis System
IEEE	Institute of Electrical and Electronics Engineers
IFRAM	International Forum for Aging Management
IGSCC	intergranular stress-corrosion cracking
INPO	Institute of Nuclear Power Operations
IPEEE	individual plant examination of external events
iPWRs	integral pressurized-water reactors
IRSN	Institute De Radioprotection Et De Surete Nucleaire
ISG-TP	International Steam Generator Tube Integrity Program
ISI	inservice inspection
JAEA	Japan Atomic Energy Agency
JNES	Japan Nuclear Energy Safety Organization
KM	knowledge management
LANL	Los Alamos National Laboratory
LER	licensee event report
LERF	large early release frequency
LPSD	low power and shutdown
LRGDs	license renewal guidance documents
LSTF	large-scale test facility
LOCA	loss-of-coolant accident
LWR	light-water reactor
MACCS	MELCOR Accident Consequence Code System
MASLWR	Multi-Application Small Light Water Reactor
MCAP	MELCOR Cooperative Assessment Program
MCCI	molten core concrete interaction
MCNP	Monte Carlo N-Particle Transport Code System
MDEP	Multinational Design Evaluation Program
MeV	million electron volts
MORs	monthly operating reports
MOX	mixed oxide

ABBREVIATIONS (Cont'd)

MSPI	Mitigating System Performance Index
NAS	National Academy of Sciences
NASA	National Aeronautics and Space Administration
NCRP	National Council on Radiation Protection and Measurements
NDE	non-destructive examination
NEA	Nuclear Energy Agency
NEI	Nuclear Energy Institute
NFPA	National Fire Protection Association
NGNP	Next Generation Nuclear Plant
NMSS	Office of Nuclear Material Safety and Safeguards
NPPs	nuclear power plants
NRC	U.S. Nuclear Regulatory Commission
NRO	Office of New Reactors
NRR	Office of Nuclear Reactor Regulation
NSIR	Office of Nuclear Security and Incident Response
NTTF	Near-Term Task Force
NUPEC	Nuclear Power Engineering Corporation
OECD	Organization for Economic Cooperation and Development
ORNL	Oak Ridge National Laboratory
PARCS	Purdue Advanced Reactor Core Simulator
PCI	pellet cladding interaction
PCMI	pellet cladding mechanical interaction
PCT	peak clad temperature
PIRT	phenomena identification and ranking table
PNNL	Pacific Northwest National Laboratory
PRA	probabilistic risk assessment
PSHA	probabilistic seismic hazard analysis
PSI	Paul Scherrer Institute
PSU	Pennsylvania State University
PUMA	Purdue University Multidimensional Integral Test Assembly
PWR	pressurized-water reactor
PWSCC	primary water stress corrosion cracking
R&D	research and development
RBHT	Rod Bundle Heat Transfer
RCS	reactor coolant system
RES	Office of Nuclear Regulatory Research
RG	regulatory guide
RPV	reactor pressure vessel
RTF	radioiodine test facility
SAMGs	severe accident management guidelines
SCALE	standardized computer analysis for licensing evaluation
SERENA	steam explosion resolution for nuclear applications
SDP	significance determination process
SGTR	steam generator tube rupture
SMR	small modular reactor
SNAP	Symbolic Nuclear Analysis Package

ABBREVIATIONS (Cont'd)

SNL	Sandia National Laboratories
SOARCA	State-of-the-Art Reactor Consequence Analyses
SPAR	standardized plant analysis risk
SRM	staff requirements memorandum
SSCs	structures, systems, and components
SSE	safe-shutdown earthquake
SSHAC	Senior Seismic Hazard Analysis Committee
SSWICS	small-scale water ingress and crust strength
TRACE	TRAC-RELAP advanced computational engine
U.S.	United States
USGS	United States Geological Survey
V&V	verification & validation
VHTR	very-high-temperature reactor
xLPR	extremely low probability of rupture

I. INTRODUCTION

In this report, the Advisory Committee on Reactor Safeguards (ACRS) presents the results of its review and evaluation of the U.S. Nuclear Regulatory Commission (NRC) Safety Research Program. The NRC maintains a Safety Research Program to:

- Ensure its regulations and regulatory processes have sound technical bases and these bases are refined as new knowledge develops.
- Prepare for anticipated changes in the nuclear industry that could have safety implications.
- Develop improved methods to carry out its regulatory responsibilities.
- Maintain an infrastructure of expertise, facilities, analytical capabilities, and data to support regulatory decisions.

The current research program, organized by the Office of Nuclear Regulatory Research (RES), is closely coupled to specific, near-term issues to support regulatory activities and initiatives in the Offices of Nuclear Reactor Regulation (NRR), New Reactors (NRO), Nuclear Material Safety and Safeguards (NMSS), Nuclear Security and Incident Response (NSIR), and Federal and State Materials and Environmental Management Programs (FSME).

RES has succeeded over the last few years in its effort to tie research activities it undertakes to near-term issues confronted by the NRC line organizations (NRO, NRR, NMSS, NSIR, and FSME).

For the purposes of this report, the ongoing research has been examined in terms of the following technical disciplines:

- advanced reactor designs
- digital instrumentation and control systems
- fire safety
- reactor fuel
- human reliability and human factors
- materials and metallurgy
- neutronics and criticality safety
- operational experience
- probabilistic risk assessment
- radiation protection
- nuclear materials and waste
- seismic and structural engineering
- severe accidents and source term
- thermal hydraulics

The interdisciplinary research effort of the State-of-the-Art Reactor Consequence Analyses (SOARCA) project and uncertainty quantification is not addressed in this report. Throughout the project, the ACRS provided reports on the technical approach of this activity.

Chapter 2 of this report provides a synoptic account of research activities in each of the technical disciplines and highlights some of the accomplishments of the work. Additional details on each of the research areas are included in Chapters 4 through 17.

In its review of the NRC Safety Research Program, the ACRS has focused on the technical and regulatory justification for the ongoing research activities. The ACRS supports research that:

- Identifies and resolves current safety and regulatory issues.
- Provides technical bases for the resolution of foreseeable safety issues.
- Develops the capabilities of the agency to independently review risk-significant proposals and submittals by licensees and applicants.
- Supports agency initiatives, including the move toward a much greater use of risk information in the regulatory process and to evolve NRC safety regulations to be risk informed and “technology neutral.”
- Improves the efficiency and effectiveness of the regulatory process.
- Maintains technical expertise within the agency and associated facilities in disciplines crucial to the agency mission and that are not readily available from other sources.

The accident at Fukushima Dai-ichi, in Japan, has increased interest in accident initiators, accident management, and consequences for accidents that are within the design basis as well as those beyond the design basis. Research to focus on the forensics of the Fukushima accident is discussed in Chapter 3. Such efforts offer a unique opportunity to better understand boiling-water reactor (BWR) severe accident progression, and thereby to develop better measures for mitigating beyond design-basis events. The NRC line organizations will benefit from research initiatives that increase the technical understanding of severe accidents.

2. GENERAL OBSERVATIONS AND RECOMMENDATIONS

Highlights of the major elements of the ongoing research dealing with the safety of nuclear power plants are presented here. Recommendations concerning these activities are also discussed.

General Observations

The U.S. Nuclear Regulatory Commission (NRC) has succeeded over the last few years in its effort to tie research activities it undertakes to near-term issues being confronted by its line organizations (Office of New Reactors (NRO), Office of Nuclear Reactor Regulation (NRR), Office of Nuclear Material Safety and Safeguards (NMSS), Office of Nuclear Security and Incident Response (NSIR), and Office of Federal and State Materials and Environmental Management Programs (FSME). Over 75 percent of research activities support specific needs of these offices. The Commission directs about 10 percent of the Office of Nuclear Regulatory Research (RES) activities through agency-mandated programs (e.g., Accident Sequence Precursor (ASP) program) and the Commission tasking memoranda. A small portion of the research budget focuses on long-term research subjects expected to be critical in 5 to 10 years.

The strategy for the identification of research subjects, through "User Need" documents, together with the associated process for the prioritization of research needs, has worked reasonably well. Research activities are yielding useful products to the line organizations in a timely manner. However, in some cases research focused on line organization needs may be terminated prematurely, precluding appropriate and needed understanding that would be of use for future regulatory issues.

Major research activities often include collaborations with other Federal agencies,

industry, universities, and international partners. Such collaborations can provide timely and thoughtful peer input while giving the agency the ability to leverage its expertise and resources on key topics of common interest (e.g., Fukushima-related topics). In addition, such collaborations provide an opportunity to help train new NRC staff as they participate in these multi-party research efforts.

The Advisory Committee on Reactor Safeguards (ACRS) continues to encourage such active collaborations to effectively share knowledge and experience that contribute to intermediate- and long-term research objectives. These collaborative programs are often the first to suffer in times of declining resources. Collaborative research should remain an integral part of agency initiatives.

Future Research Focus Areas

In its 2012 report to the Commission on the NRC Safety Research Program (NUREG-1635, Vol. 10), the ACRS noted that the Japan Near-Term Task Force (NTTF) report provides detailed near-term and long-term recommendations for ensuring nuclear reactor safety based on initial lessons learned from the Fukushima event. Many of these recommendations require research to support their effective implementation. Furthermore, in the coming years, as data from the Fukushima recovery effort are collected, new insights could point to the need for additional work. This is discussed in more detail in Chapter 3.

In its review and evaluation of the NRC Safety Research Program, the ACRS has identified several topical areas for research that will support NRC line organizations in implementing various lessons-learned from Fukushima to the U.S. nuclear reactor fleet. These include:

- protection from external hazards
- protection from severe accidents
- emergency response and severe accident management capabilities
- accident tolerant instrumentation
- improved understanding of severe accident phenomena

The ACRS continues to recommend that the Commission develop an integrated plan for providing the necessary technical basis for implementation of the lessons learned from events that occurred at the Fukushima Dai-ichi nuclear plant site.

Major Observations on Individual Areas of Research

Major observations, conclusions, and recommendations concerning specific research activities are summarized below. Additional details on the research activities in the various technical disciplines are provided in Chapters 4 through 17.

Advanced Reactor Designs

The U.S. Department of Energy (DOE) has decreased funding in advanced reactors that are not based on light-water reactor technologies. Therefore, NRC research is properly being refocused on generic issues for advanced reactors.

Safety research efforts on small modular reactor (SMR) designs are in their early stages. The NRC has identified important issues for licensing of proposed designs (e.g., multi-module operation and performance of unique safety systems). These efforts provide significant input to the development of safety research necessary for future reactor licensing activities. Any future research efforts are being appropriately tied to the expected design certification issues identified for the mPower and NuScale concepts.

Digital Instrumentation and Control Systems

Digital systems safety assurance continues to be a challenge for the NRC. The NRC and the Electric Power Research Institute (EPRI) have independently evaluated and identified the limitations of failure (fault) modes and effects analysis (FMEA) for regulatory assurance of complex logic in digital systems – particularly in the presence of interactions and feedback paths. Both organizations have been researching a broader range of hazard analysis (HA) techniques for evaluating safety assurance. The ACRS encourages close collaboration on digital system research under the memorandum of understanding (MOU) on Cooperative Nuclear Safety Research between the two organizations.

Quantifying the reliability of digital systems in probabilistic risk assessments (PRAs) is a major challenge. The ACRS has noted the progress that has been achieved in analysis of digital system failure modes. The use of these results, however, is not coordinated with digital system PRA research.

The ACRS continues to see a lack of integration of control of access, safety, and cybersecurity in the design stage and licensing as an impediment to ensuring secure digital instrumentation and control (DI&C) safety systems.

Fire Safety

The NRC's fire safety research program continues to make progress developing an understanding of fire events and an assessment of risk from fire damage in nuclear power plants. Structured collaboration with industry provides cost-effective solutions and technical insights that surpass independent efforts. The NRC is a leader in national and international fire safety research. The focus and priorities for current research projects are determined primarily by user-identified needs. This process has

been responsive to immediate and near-term technical issues. It should remain an important part of integrated planning. Where identification of need is clear and beneficial, research priorities and programs should more actively anticipate additional emerging applications and potential intermediate- to long-term requirements that are not fully dictated by current user needs. Guidance is currently being developed for the assessment of risk during low-power and shutdown operating modes. Continued research is needed to evaluate issues such as fire initiation frequencies, human-caused fires, effectiveness of detection and suppression capabilities, and propagation of heat and smoke through compromised fire barriers that are uniquely associated with personnel activities and system configurations during plant shutdown.

Research projects should address early detection of incipient fire, the effects from fire damage and heat on fiber optic cables, the effects of heat on digital equipment, and the effects of smoke damage to digital signal processing and computation modules.

Reactor Fuel

Current research addressing fuel fragmentation, axial relocation, and dispersal is very well structured, has made excellent progress, and is well on its way to generating experimental and analytical results to support regulatory decisions.

The FRAPCON and FRAPTRAN fuel performance codes meet most near-term agency needs. There is ample capability to assess risks of fuel failure due to fuel center melting, excessive mechanical strain, and departure from nucleate boiling events. In the future, light-water reactor (LWR) operations may include more load following that may increase the likelihood of pellet clad interaction. The NRC is developing capability to quantitatively assess pellet cladding interaction (PCI) fuel failures

during anticipated operational occurrences (AOOs) for current or future fuel designs.

Advances in computing power and computational simulation are making it possible to examine fuel performance in vastly more detail than is done with either FRAPCON or FRAPTRAN. Whether such detail is needed will depend critically on what efforts are made by licensees to extend fuel burnup beyond the current regulatory limit of 62 gigawatt-days per metric ton (GWd/t) and the amount of experimental data provided to support these proposed changes to regulatory limits. Consequently, there will be a continuing need for the agency to independently evaluate the safety of proposed changes in the nature and burnup limits of reactor fuels.

Human Factors and Human Reliability

The human factors (HF) and human reliability analysis (HRA) research program has evolved into a carefully coordinated series of projects that are extending knowledge and providing improved methods to be used in regulatory activities.

The Integrated Decision-tree Human Event Analysis System (IDHEAS) HRA methodology program has integrated experience from the International and U.S. HRA Empirical Studies to identify the strengths and weaknesses of existing HRA methods and develop a hybrid approach. The methodology needs to be tested on a large-scale application to ensure that it is practical. The guidance must be improved, especially to strengthen the qualitative analysis.

The ACRS has identified three areas of HF and HRA research that could benefit from increased emphasis in the future: (1) the work on medical applications should receive more emphasis, (2) the development of HRA and HF approaches to support NSIR applications needs to be explored, and (3) the work on the effects of degraded I&C

systems on human performance should be expanded.

Materials and Metallurgy

The ACRS supported the initial vision of the proactive materials degradation assessment (PMDA) and the later expansion of its original scope to include concrete structures and electrical cable insulation. The expanded materials degradation assessment (EMDA) program, under the joint sponsorship of the NRC and DOE, has identified key areas of concern for subsequent license renewal operation (time frames of 60 to 80 years). The current research programs are adequate for all areas of concern except one. Recent research indicates that the exposure of stainless steels and nickel-base alloys to high-temperature water in the absence of radiation damage can result in a significant decrease in tearing resistance and fracture toughness. If confirmed, this effect is a potential safety issue and NRC research on this topic should be pursued.

The NRC research program is conducting effective work in: the xLPR (extremely low probability of rupture) program; the improvement of nondestructive evaluation (NDE); and the confirmation of industry steam generator inspection and integrity models.

The ACRS continues to support the agency's active participation in international efforts relating to materials degradation, such as the International Cooperative Group on Environmentally Assisted Cracking (ICG-EAC) and the recent cooperative agreement between the NRC and the French Institute De Radioprotection et de Surete Nucleaire (IRSN) to develop techniques for inspection of coarse-grained materials in dissimilar metal welds.

Neutronics and Criticality Safety

The current NRC research programs on neutronics and criticality safety are

appropriately prioritized and are well supported by user needs.

Expanded application capability, improved accuracy, and enhanced computational efficiency demands for neutronics and criticality analyses should be achieved as a result of both near term and long term research programs. Licensees of operating reactors continue to optimize core designs using improved analytical techniques, some of which require full core, coupled approaches to safety analyses. In addition, similar capabilities must be applied to assure appropriate safety analyses for integral small modular and large advanced reactors.

Operational Experience

The operational experience research programs continue to provide data and tools necessary for regulatory decisionmaking.

The primary sources of operating experience data are the Institute of Nuclear Power Operations (INPO) Equipment Performance and Information Exchange System (EPIX), Licensee Event Reports (LERs), and inspection reports. These sources provide information about operational failures. When these data are used to support risk analysis, they must be augmented with estimates of the successes (i.e., the number of equipment demands or operating times). The successes are highly plant-specific, involving operating practices and details of surveillance and testing procedures.

Many plant-specific PRAs have documented thorough compilation of success data. Lacking accurate plant-specific success data, it must be recognized that there is substantially greater uncertainty in the count of successes compared to the count of failures. Likewise, any generic industry-wide failure rate data should include substantial uncertainty caused by plant-to-plant variability in both the number of failures and successes.

Some years ago, the NRC's former Office for Analysis and Evaluation of Operational Data (AEOD) published a number of reports that investigated this issue and provided industry-wide failure rate estimates for a variety of equipment. RES should examine the impact of the uncertainty in success data in their applications and analyses. Expanding the previous work of AEOD with research to fully incorporate these uncertainties may be appropriate.

Probabilistic Risk Assessment

A substantial fraction of probabilistic risk assessment (PRA) research resources is allocated to immediate user needs and short-term requirements to support existing PRA model infrastructure for the Reactor Oversight Process. The ACRS continues to encourage increased sharing of the Standardized Plant Analysis Risk (SPAR) model maintenance and support activities among the regional offices, headquarters staff, and contractors, allowing RES to focus more effectively on advancement of state-of-the-art risk assessment methods and practices.

The ACRS continues its strong support for the Level 3 PRA project. It will improve the understanding of integrated site-level risk and provide a context to define needs for additional intermediate- and long-term research. The ACRS recommends that RES should use evolving knowledge and insights from the Level 3 PRA project to risk-inform initiatives for specific research that may be proposed as a consequence of NRC and industry responses to the Fukushima Dai-ichi accidents.

Proposed new small modular reactor designs introduce regulatory challenges that must be addressed to understand and manage the risk from potential single-unit, multiple-unit, and site-level accidents. The ACRS recommends that RES should pursue a pilot study to apply the risk-informed licensing framework proposed

in NUREG-1860, "Feasibility Study for a Risk-Informed and Performance-Based Regulatory Structure for Future Plant Licensing, Volumes 1 and 2," for a specific small modular reactor design. The study should address design, operations, and site-level issues that affect accident progression, mitigation options, emergency planning, and offsite consequences.

Substantial efforts have been made to improve security against potential physical and cyber attacks on our operating nuclear power plants. New plants will further integrate security protections from the initial stages of their designs. Despite these efforts, concerns remain that the applied security controls may not be allocated optimally to cope with the full spectrum of potential threats. The ACRS recommends that RES should initiate a research project and pilot applications to examine the use of quantitative risk assessment methods to inform security programs and practices.

During 2013, decisions were made to permanently shut down four US reactors. Others may follow over the next few years. These actions raise questions about whether the NRC has fully addressed the risks from decommissioning activities, including disposal of used nuclear fuel and high-level wastes. The ACRS recommends that RES should initiate a project to examine how quantitative risk information can be used to inform regulatory decisions in these interrelated disciplines.

RES has completed an important update to NUREG-1855, "Guidance on the Treatment of Uncertainties Associated with PRAs in Risk-Informed Decision Making," which contains practical guidance on methods to systematically identify, document, and quantify sources of uncertainty. However, a disciplined assessment of uncertainty is not yet applied consistently throughout the agency. The ACRS recommends that RES should initiate efforts to ensure that an appropriate characterization of uncertainty is performed in all agency analyses.

The ACRS encourages active collaboration among RES, other Government agencies, industry research organizations such as EPRI, and universities to effectively share knowledge and experience that contribute to intermediate- and long-term research objectives. These collaborative programs are often the first to suffer in times of declining resources. Collaborative research should remain an integral part of RES initiatives.

Radiation Protection

The staff has developed an appropriate and robust research program in the area of radiation protection. This program includes radiation protection of workers and the public and radiological assessments related to radiation exposure and health risks around NRC-licensed nuclear facilities.

The ACRS is supportive of RES's participation in national and international efforts relating to radiation protection. These collaborations provide excellent opportunities for the NRC staff to benefit from the work of other organizations in the United States and around the world.

Nuclear Materials and Waste

Research activities in the general areas of nuclear materials and waste reflect the current hiatus in the resolution of policy issues. The current activities address issues encountered or anticipated in the inspection and monitoring activities.

Electrochemical separation has been suggested as a means to facilitate the safe disposal of waste. RES has a research program to better understand the possible separation processes and hazards that could arise in the possible use of electrochemical preprocessing of waste for disposal. This is of necessity a very exploratory effort. Further detailed work in this area should await more definitive proposals from potential licensees.

Seismic and Structural Engineering

The NRC seismic and structural research program in support of regulatory activities is being conducted under a well-developed research plan that has been broadly reviewed for both technical quality and programmatic elements. The program funds state-of-the-art work via contracts to several renowned organizations in the field, including national laboratories and universities, as well as international cooperative programs and collaborative research with other governmental agencies such as DOE. This program will adequately support the NRC staff's capabilities to evaluate potential seismic and flooding risks to U.S. nuclear plants.

Severe Accidents and Source Term

The NRC makes use of its severe accident expertise and analysis capabilities to support regulatory decisions for operating nuclear power plants and for certifying new and advanced reactor designs. Severe accident analysis tools also help in the transition to a more risk-informed regulatory framework. The agency's long-term severe accident and containment response evaluation development plan focuses on two areas: (1) maintenance and development of its severe accident computer codes and (2) continued collaboration in international experimental research programs.

The ACRS agrees with the approach that the NRC staff has developed to support regulatory decisions for severe accidents via computer code development validated by experimental data analysis. This approach has successfully allowed the NRC to maintain and update its modeling capabilities for severe accident analyses. Ongoing Fukushima assessments may identify some deficiencies in BWR-specific and ex-vessel modeling capabilities. The NRC should participate in efforts to obtain data on accident progression in the

damaged Fukushima reactors. These data can be used to refine severe accident models for boiling-water reactors.

Thermal Hydraulics

Excellent progress has been made in developing and incorporating the NRC's systems thermal-hydraulics code, TRACE, into the regulatory process. Further development should focus on implementation of the four-field thermal-hydraulics model, as recommended by the TRACE peer-review group. The research program on interfacial area transport should be phased out as the results are of limited value for TRACE applications.

The ACRS is supportive of the agency's active participation in international collaborative efforts, as they take advantage of facilities that are of a scale and capability that do not currently exist in the United States. They also draw on the expertise of international partners, who have continued to maintain a high level of capability in thermal-hydraulics. Complementary development of unique U.S. facilities to support confirmatory accident analyses for new fuel and reactor designs should be seriously considered. Integral tests would enhance confidence in regulatory analysis of new reactor designs. Such integral tests cannot be carried out in any existing facilities.

NRC currently has modest, but productive, efforts in the area of computational fluid dynamics (CFD) through the use of commercial CFD codes, which have played a role in improving the technical bases for certain licensing decisions. In this direction, licensees are and will continue to capitalize on the extraordinary advances in computing power and computational science to address many critical safety issues, e.g., prediction of the behavior of full-scale components, such as advanced accumulators, based on small-scale experiments. The agency should maintain

independent confirmatory capabilities that keep pace with such developments in industry. The ACRS has suggested strategies to establish and maintain such capability.

3. FUKUSHIMA FORENSICS: UNDERSTANDING SEVERE ACCIDENT PROGRESSION

Eventually the damaged reactors at the Fukushima Dai-ichi site will be opened and dissected. This process presents an opportunity for the collection of data and observations concerning the progression of severe reactor accidents in boiling-water reactors (BWRs) that at least parallels the opportunity provided by the recovery of the Three Mile Island Unit II (TMI-2) for understanding severe accidents in pressurized-water reactors (PWRs). The understanding provided by TMI-2 forensics led to a wide range of changes in the modeling of severe accidents in PWRs. 'Separate-effects' tests were conducted to put quantitative substance on qualitative insights gained from examinations of the fuel and structures, fission products, and their interactions throughout the reactor coolant system. Unfortunately, there have been a very limited number of BWR-specific tests, and similar advances were not made in the modeling of BWR accidents. Forensic efforts at Fukushima, assisted by international collaborations for conducting additional analysis and companion experiments, offer significant potential for improved understanding of beyond-design-basis accident behavior, associated fission product source term release and transport, as well as the ability of severe accident analyses to inform onsite and offsite actions to mitigate the consequences of such events.

The progression of severe reactor accidents in BWRs may be quite different than accident progression in PWRs. Channel boxes and the cruciform control blades used in BWR fuel assemblies would certainly affect the early stages of cladding oxidation, fuel rod heatup, and core degradation. Continued degradation and accident progression could be affected by natural convection to the massive steel structures making up steam separators and steam

dryers above the reactor core. The BWR geometry with its internal structures represents a shorter natural convection transport path than the natural convection to the steam generators in PWRs. Based on results from a limited number of smaller scale prototype BWR experiments, the MELCOR code, with BWR specific models incorporated into it, predicts that BWR relocation is an incoherent phenomenon with small amounts of material draining through the lower core support plate into the lower reactor plenum. However, standard MELCOR code models and industry severe accident codes assume that liquefied BWR fuel and cladding accumulate within the core region similar to what was observed in the PWR accident at TMI-2. Forensic investigations into the reactor cores at Fukushima can certainly help resolve these uncertainties.

Based on what is currently known about the events at Dai-ichi, it is expected that there remained sufficient water to quench the core material in the lower plenum below the core or in the pedestal region below the reactor pressure vessel.

In-vessel, massive steel structures making up over 200 control rod drives (CRD) in the lower plenum may also provide heat sinks to quench relocating core debris. These CRD structures and instrumentation penetrations may also serve as fins for heat removal. Although water inventory and steel structures in the BWR lower head may temporarily quench liquefied core debris, long-term debris stabilization requires continued water addition to the reactor pressure vessel with associated removal of decay heat to an ultimate heat sink.

If cooling of core debris in the lower plenum of a BWR reactor vessel cannot be maintained by continued water injection (or

if the relocated debris has been fragmented to sizes sufficiently small that it is not coolable), the debris mass will heat and remelt. Contact of this material with the vessel lower plenum may lead to local failures of the vessel lower head instrumentation tube or drain line penetrations with release of the core material. This would add to the incoherency of the accident progression and lead to different end-states than currently simulated in ex-vessel models in severe accident analysis computer codes.

The BWR instrumentation tubes are thought to be more vulnerable to failure than the more massive and numerous control-rod drive penetrations. However, the drain line, which is located at the bottom center of the vessel and has no in-vessel structures, has the potential to be even more susceptible to ex-vessel tube failure. Melt expulsion from the reactor vessel into the BWR drywell will lead to ex-vessel core debris interactions, which will be somewhat different than ex-vessel interactions PWRs. The large reactor cavities of many PWRs will keep debris separated from the reactor containment boundary. However, the drywell floor of the Mark I BWR containment has a small sump. If the volume of debris expelled from the vessel exceeds the volume of the sump, molten debris can flow across the drywell floor and impinge directly on the carbon steel containment boundary. The presence of water on the drywell floor, as well as radiation and convective heat transfer from the debris to surrounding structures, could largely affect the integrity of drywell liner or the drywell head seals in the containment.

Until now, modeling of the progression of severe BWR accidents has largely been speculation augmented with the results of a few small, stylized tests that did not attempt to represent all the features of the reactor core, the core support structures, the reactor vessel, or the containment. The inspection and dissection of the Fukushima Dai-ichi reactors, along with materials

sampling at selected locations, will provide an opportunity to validate these modeling assumptions; and where the models are not valid, the data will provide the basis for improved modeling for accident progression and fission product transport.

Post-accident forensic evaluations from the damaged Fukushima Dai-ichi plants have the potential to increase international reactor safety. Similar to what occurred in the TMI-2 post-accident examinations, Fukushima Dai-ichi evaluations will, by necessity, be guided by what is learned from initial observations into the reactor vessel and/or containment. To maximize the potential benefits of a Fukushima Dai-ichi reactor inspection effort, the ACRS recommends that current international efforts be expanded and a consortium be formed to assist the Japanese and provide international input related to areas of interest for inspection.

ACRS experience indicates that the types of data that need to be collected fall within these topical areas:

- initial stages of core degradation
- late stage core degradation
- behavior in the lower plenum
- degradation of upper core structures and radionuclide deposition
- observed materials and radionuclide deposition and behavior in the drywell
- observed materials and radionuclide behavior in the reactor building

The information needs in each of these categories are based on phenomenological modeling uncertainties. The ACRS expects information, such as the operation of cooling systems (e.g., high-pressure coolant injection (HPCI), reactor core isolation cooling (RCIC), and isolation condenser (IC) and the operation of instrumentation, would

also be addressed by other international efforts to understand severe accident management. This information will also be crucial as input for modeling the physical processes that need to be addressed. Similarly, information on the timing and nature of seawater injection will be crucial inputs to the modeling. Even with international support, funding will be limited for obtaining the desired data. Hence, it is essential that this international effort develop a consensus with respect to prioritized data needs.

As discussed within this report, the U.S. Nuclear Regulatory Commission (NRC) has a long history of successfully leveraging its resources by relying on collaborations in international research programs. The body of knowledge gained from NRC's past experimental work and that

obtained from international experimental programs are systematically incorporated into the MELCOR accident analysis code.

The ACRS recommends that the NRC proactively engage with the U.S. Department of Energy, Japanese research organizations, and others in the international community, to focus on the forensics of the Fukushima accident. Such efforts offer a unique opportunity to better understand BWR severe accident progression, and to develop better measures for mitigating future beyond design-basis events.

4. ADVANCED REACTOR DESIGNS

Background

Since 2005, U.S. Nuclear Regulatory Commission (NRC) research on advanced reactor designs has focused on assessment of its research needs and its planned safety research to support the review of the Next Generation Nuclear Plant (NGNP), sponsored by the U.S. Department of Energy (DOE). DOE has interacted with reactor designers, potential process heat users, and industrial and international organizations to support the next-generation nuclear plant (NGNP) design development needs for the thermal-spectrum gas-cooled graphite-moderated reactor concept, the so-called Very High Temperature Reactor (VHTR).

The DOE effort was reinforced by the passage of the Energy Policy Act of 2005 (EPAAct 2005)¹, which authorized appropriation of funds for research and construction activities for the NGNP project. DOE selected the VHTR as the lead design concept for the NGNP. Specifically, the VHTR program is focused on this type of reactor design, and EPAAct 2005 authorizes the NRC to collaborate with DOE in safety research related to licensing issues as the project proceeds through licensing to construction and operation. As DOE is reevaluating its research and development efforts for non-LWR (non-light-water reactor) advanced reactor concepts, the VHTR remains one of the major initiatives.

Since 2010, interest has grown in deploying small modular reactors (SMRs). Recent indications that applications might be received for one or more SMRs in the next couple of years with DOE matching support has generated a corresponding need to identify safety research topics to support

review of licensing applications for these designs. SMR integral pressurized-water reactors (iPWRs) vendors have been identified as most likely to submit applications in the near term. These include mPower and NuScale.

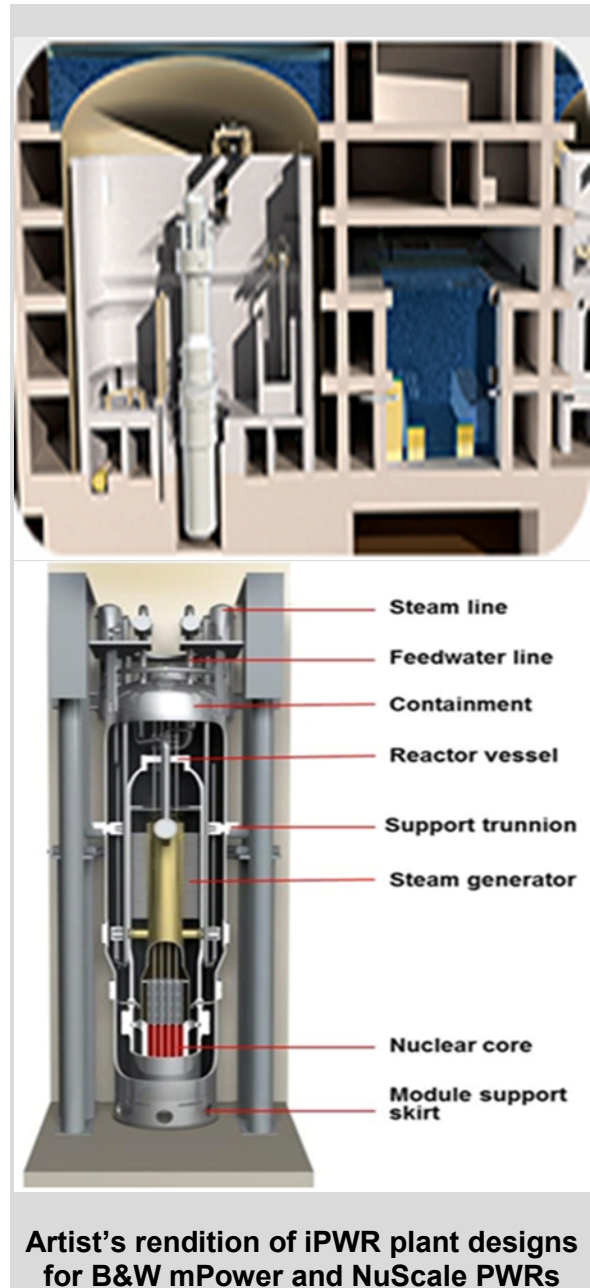

¹ See Subtitle C: Next Generation Nuclear Plant Project.

For both non-LWR advanced reactors and SMRs, the NRC staff has completed initial

activities to provide the proper background information for the lead designs. Such activities included:

- Development of key information sources for the technologies.
- Conduct of a Phenomena-Identification and Ranking Table (PIRT) exercise for each design to identify the key safety-significant phenomena that require additional research and development. These key phenomena are associated with tools, standards, data, etc., required for the design and licensing review of each reactor technology.

Research conducted for advanced reactor designs is closely coordinated with severe accident and source term research and with research on human factors, digital instrumentation and control systems, and materials and metallurgy.

Current Research Activities

VHTR ACTIVITIES

The NRC staff has focused on the development of appropriate evaluation models/methods/guidance using information from past prismatic gas-cooled reactor designs and pebble-bed designs as well as the current conceptual VHTR designs from the industrial teams working with DOE and its national laboratory contractors. Based on the 2011 HTGR [high-temperature gas-cooled reactor] NRC Research Plan, a number of research topics were considered by the staff to support licensing:

- plant safety analysis including thermal-fluids and accident analysis
- nuclear analysis
- fuel performance and fission product behavior
- high-temperature materials performance

- graphite performance
- safety issues related to process heat applications
- structural analysis (with particular focus on high-temperature effects)

The research plan was comprehensive. However, because the final VHTR design has yet to be determined, the plan focused on the research and development (R&D) aspects that are applicable to the range of possible VHTR reactor designs. One area that has received needed attention was the development of evaluation models and tools covering four areas: (1) thermal-fluid analysis, (2) nuclear analysis, (3) fuel performance, and (4) fission product release and transport. The staff also identified a number of data needs for the HTGR. Issues that specially deserve attention include steam-graphite oxidation, models for graphite dust production during operation and necessary limitations on dust accumulation, and approaches for dealing with uncertainty in the selection of mechanistic scenarios.

By 2012, DOE had submitted a series of white papers to the NRC on topics identified by research needs as key issues: defense in depth (DID); high temperature materials; fuel qualification; mechanistic source terms; structures, systems, and components (SSCs) safety classification; emergency planning; licensing basis event selection; and PRA. The staff reviewed the DOE white papers and issued draft assessments on fuel qualification, mechanistic source terms, defense-in-depth, licensing basis event selection, and safety classification of SSCs.

The staff also issued a final summary report for the following NGNP licensing issues:

- (1) licensing basis event selection
- (2) source terms
- (3) containment functional performance

(4) emergency preparedness

Since a final design had not been selected and no owner/operator had been identified for the NGNP project, the staff emphasized that statements in this assessment do not provide final regulatory decisions.

SMR ACTIVITIES

Work on SMRs is in its early stages, but the staff has identified some generic safety issues that are likely to be important for licensing decisions. Technical issues related to thermal-hydraulic scaling, digital control and instrumentation, system integration, licensing basis events, and multi-module human-systems interface are especially important with respect to safety and licensing.

Assessment and Recommendations

The 2011 HTGR Research Plan is logically focused on generic issues that address licensing needs. However, the final VHTR design has yet to be identified. Given DOE's decreased funding in non-LWR advanced reactor design and without an applicant or a specific design, existing research is properly being refocused on generic issues for advanced reactors.

Safety research efforts on SMR designs is in early stages. The NRC has identified important issues for licensing of these designs. These efforts provide a significant input to the development of safety research necessary for future reactor licensing activities. Any future research efforts are being appropriately tied to the expected design certifications issues identified for mPower and NuScale.

5. DIGITAL INSTRUMENTATION AND CONTROL SYSTEMS

The current operating fleet of nuclear power plants continues to transition to digital technology for reactor protection and engineered safeguards systems. New reactor designs have proposed fully digital control rooms and small modular reactor (SMR) vendors will soon submit applications for design certifications using digital technology. Application of this technology must preserve the critical attributes of redundancy, independence, deterministic processing behavior, defense-in-depth, and diversity to ensure the reliable shutdown and actuation of protection and safeguards systems. The application of this technology also brings with it new concerns regarding control of access to the systems and cybersecurity.

The new systems using digital technology must be designed such that they can be reviewed and analyzed to verify these attributes—upon which safety depends—against engineering deficiencies, common cause failures, unwanted intrusion, unwanted interactions, and hardware failures.

Fundamentally, safety systems involve simple actuations and do not involve complex feedback and control functions. Traditionally, safety systems were kept simple to preserve these properties. In contrast, digital systems, with interconnections across redundant divisions, across safety-grade and lower-grade systems, and across monitored and monitoring components, have increased considerably the potential to degrade a safety function and compromise safety division independence.

With these concerns and considerations in mind, the 2010-2014 Research Plan was organized into five major topic areas:



*Candidate Generation III Nuclear Power Plant
Control Room*

- safety aspects of digital systems
- security aspects of digital systems
- advanced nuclear power concepts
- knowledge management
- carry-over projects from the fiscal year 2005-2009 digital instrumentation and control (DI&C) research plan

Additionally, the Office of Nuclear Regulatory Research (RES) responds to emergent program offices support needs. The current scope of research projects balances previously identified research needs with new specific user need support requests.

A recent RES reorganization combined the DI&C and electrical research into one branch: the Instrumentation, Control, and Electrical Engineering Branch. The significant new electrical research projects include electrical cable qualification and condition monitoring in extended license intervals, performance of nuclear power plant (NPP) vital 125 volts direct current (Vdc) station battery in normal and extended station blackout conditions, and susceptibility of NPPs to faults in offsite power grids. The ACRS plans to include the electrical research projects in its future

review and evaluation of the NRC safety research program.

Safety assurance of digital systems continues to be a challenge for the U.S. Nuclear Regulatory Commission (NRC). NRC and the Electric Power Research Institute (EPRI) have independently evaluated and identified the limitations of Failure (Fault) Modes and Effects Analysis (FMEA) for regulatory assurance of complex logic in digital systems – particularly in the presence of interactions and feedback paths. The NRC and EPRI presented the results of these evaluations to the Advisory Committee on Reactor Safeguards (ACRS) on September 19, 2013. Both the NRC and EPRI have been researching a broader range of hazard analysis (HA) techniques for evaluating safety assurance. Office of New Reactors (NRO) is proposing a new Design Specific Review Standard (DSRS) for the mPower SMR and has included the use of hazard analysis to improve regulatory efficiency and effectiveness in the safety evaluation of a digital system. The ACRS encouraged the close NRC and EPRI collaboration on digital system research under the research memorandum of understanding (MOU).

One of the means for safety assurance of digital systems is through better practice in software verification and validation, configuration management, test documentation, software unit testing, software requirements specifications, and life cycle management. RES has completed new revisions to the Regulatory Guides - RG 1.168, 1.169, 1.170, 1.171, 1.172, and 1.173. The revisions updated these guidance documents to the more current Institute of Electrical and Electronics Engineers (IEEE) standards. The ACRS reviewed and supported issuing these updated regulatory guides.

Another major challenge is quantifying the reliability of digital systems in probabilistic risk assessments (PRAs). Several projects

have resulted in the issuing of NUREGs that benchmarked methods for reliability modeling and assessing traditional probabilistic risk assessment (PRA) methods for DI&C systems. Another project is developing models of digital safety systems integrated with reactor safety analysis tools as well as for use in PRAs. Research Information Letter 1002, "Identification of Failure Modes in Digital Safety Systems – Expert Clinical Findings," documented recent work on utility of digital system failure modes in safety assurance. The ACRS noted the significant progress in analysis of digital system failure modes, but is concerned that the use of these results is not coordinated with digital system PRA research.

The NRC continues to implement new regulatory oversight for cyber security. Current policy and regulatory guidance do not have enforcement authority during digital system safety reviews; the agency has recognized the issue and is taking steps to improve oversight in this area. Several initiatives have been developed by the program offices to ensure more effective internal collaboration between the Office of Nuclear Security and Incident Response (NSIR), Office of Nuclear Reactor Regulation (NRR), and Office of New Reactors (NRO). NSIR developed an interim framework and interoffice instruction to provide staff guidance and NRR is piloting earlier cyber review considerations during the Diablo Canyon digital protection systems licensing reviews.

The use of digital technology for plant systems and networks for communication of data and control of actuation signals introduces significant vulnerabilities to control of access to critical plant controls and monitoring functions. These vulnerabilities are further exacerbated when bi-directional software communications outside of the plant and onto the Internet are allowed. These features also significantly increase the potential for compromise of other cybersecurity

concerns. Analog systems generally required a physical presence to access systems and controls to alter equipment operating and output parameters and were more amenable to supervisory and procedural controls. The ACRS still is concerned that the review of safety system design via RG 1.152, "Criteria for Use of Computers in Safety Systems of Nuclear Power Plants," explicitly prohibits the review of DI&C design features for their ability to provide satisfactory control of access and cybersecurity design during the licensing process. The control of access and cybersecurity features per RG 5.71, "Cyber Security Programs for Nuclear Facilities," may not be fully evaluated until after the design is complete (upwards of 3 or 4 years after licensing) and that review would have to be performed by NRC site inspectors that may not be experienced in design of digital systems and in cybersecurity threats and solutions. Thus, there is not an integration of design and cybersecurity review during the DI&C licensing process. The ACRS continues to see this nonintegrated approach as a vulnerability to achieving assuredly safe and secure DI&C safety systems. The ACRS agrees that review methods and framework development initiatives similar to those in progress as noted above are needed. However, regulatory guidance and rule development that focus on this problem should be developed to assure design solutions allow only one-way hardware based (without any software involved) data flow to locations external to the plant in both the design of new plants or backfits of DI&C technology into existing plants.

Recognizing the ongoing need for knowledge management in digital safety systems, RES has been consulting with experts from other regulatory organizations, academia, other Federal agencies, and other industries. Learning from their knowledge, RES is improving its internal research capability.

In its 2012 report to the Commission, the ACRS noted that the events at Fukushima illuminated the need for improved, hardened instrumentation that can survive anticipated severe accident environments and provide critical plant condition information. Examples include reactor pressure, temperature, and water level conditions inside the reactor vessel; spent fuel pool temperature and actual water level; real time hydrogen concentrations at key locations (not a sampling system); or the location of core materials. Such data are critical for the operators to correctly assess the plant status and implement appropriate severe accident mitigation strategies. Determining whether core cooling was being achieved was hampered by the lack of reliable instrumentation. In addition, this new instrumentation needs to be either non-electrical or have dedicated power sources that are available for weeks and possibly longer without recharging. The NRC accepted the ACRS recommendation in this area and RES is leading a Tier 3 Fukushima Near-Term Task Force team for consideration of these needs. RES is collaborating with research efforts in DOE and EPRI on this topic.

The 2010- 2014 DI&C Research Plan is nearing its conclusion as a planning guide. The ACRS would like to be informed when the 4-year plan for 2015-2018 will be developed so a briefing to the ACRS DI&C Subcommittee can be scheduled.

6. FIRE SAFETY

Background

The current focus of the fire safety research program is to support the U.S. Nuclear Regulatory Commission's (NRC's) regulatory needs during licensee transitions to risk-informed, performance-based fire protection programs that meet the requirements of Title 10 of the *Code of Federal Regulations* (10 CFR) 50.48(c) and the referenced 2001 edition of the National Fire Protection Association (NFPA) Standard NFPA-805. Continuing research activities also develop improved information to support deterministic fire protection programs for licensees that do not adopt a risk-informed approach. In addition to direct support for currently operating reactors, the fire safety research programs also provide input to new reactor licensing reviews and assessment of the risk from fires in new reactor designs.

Current Research Activities

The NRC research activities in fire safety are depicted in Figure 1. Research activities primarily support programs in NRR and, to a lesser extent, the Office of Nuclear Material Safety and Safeguards (NMSS). These activities are grouped into four technical areas:

- fire modeling,
- fire testing,
- fire & electrical systems analysis
- fire risk assessment.

Efforts are also underway on fire research knowledge management (KM). The following sections briefly discuss the major projects in each area.

Fire Modeling

Fire models provide a phenomenological basis for the evaluation of fire growth,

detection, and suppression, and the analysis of potentially risk-significant fire scenarios.

In 2007, the NRC, the Electrical Power Research Institute (EPRI), and the National Institute of Standards and Technology (NIST) completed a collaborative study for verification and validation (V&V) of fire models used to analyze NPP fire scenarios. The results of this study were documented in the seven-volume NUREG-1824 report, "Verification and Validation of Selected Fire Models for Nuclear Power Plant Applications." That effort identified strengths and weaknesses in each code with respect to specific fire modeling issues.

In 2008, a phenomena identification and ranking table (PIRT) study (NUREG/CR 6978, "A Phenomena Identification and Ranking Table Exercise for Nuclear Power Plant Fire Modeling Applications") was completed to assess the predictive capabilities of these fire models and to identify important fire modeling capabilities needed to be further improved.



International Testing Program for High Energy Arc Faults (HEAF)

The NRC is leading an international Organization for Economic Cooperation and Development/Nuclear Energy Agency (OECD/NEA) testing program for HEAF. The primary objective of this project is to obtain fire data on the HEAF phenomena known to occur in NPPs through carefully designed experiments.

In 2012, the Office of Nuclear Regulatory Research (RES) completed another collaborative project with the EPRI and NIST to develop an integrated “Nuclear Power Plant Fire Modeling Application Guide,” NUREG-1934, for the approved models. The Guide describes the capabilities of each fire modeling tool to evaluate specific phenomena during realistic fire scenarios, including limitations, precautions, and lessons learned from practical applications. The Guide will benefit risk analysts who use the fire models to evaluate potentially important fire scenarios, and it will support inspection efforts that use the models as input to the significance determination process (SDP).

The NRC is continuing to update the fire modeling tools, expand the verification and validation (V&V) effort for the fire models, and to develop additional model input data. The NRC published Supplement 1 to NUREG 1805, “Fire Dynamics Tools (FDTs) Quantitative Fire Hazard Analysis Methods for the U.S. Nuclear Regulatory Commission Fire Protection Inspection Program,” that will include the THIEF (Thermally Induced Electrical Failure) model and updated versions of the spreadsheets that are currently documented in NUREG-1805 in July 2013.

Fire Testing

This element of the research program includes three major projects.

CHRISTI-FIRE

The Cable Heat Release, Ignition, and Spread in Tray Installations during Fire (CHRISTI-FIRE) experimental program is an effort to develop a more realistic understanding of the burning behavior of grouped electrical cables. The tests are conducted with realistic cable tray configurations and loadings, and they include cables with thermoplastic and thermoset insulations. The quantitative data collected by this project are used to develop

more realistic cable fire models for probabilistic risk assessments (PRAs) and to enhance the predictive capabilities of fire modeling codes.

During Phase 1 of CHRISTI-FIRE, a simple model of flame spread in horizontal tray configuration FLASHCAT (Flame Spread over Horizontal Cable Trays) was developed based on semi-empirical estimates of lateral and vertical flame spread and measured values of heat of combustion, heat release rate, and residue yield. The Phase 1 was completed in 2011 and the results were documented in NUREG/CR-7010, “Cable Heat Release, Ignition, and Spread in Tray Installations during Fire (CHRISTIFIRE), Phase 1: Horizontal Trays,” Volume 1, issued in July 2012.

During Phase 2 of the CHRISTIFIRE project, tests were conducted to examine flame spread on cables in vertical tray configurations and the impact of an enclosure on cable flame spread in multiple horizontal trays. The results of the Phase 2 tests were documented in Volume 2 of NUREG/CR-7010, “Cable Heat Release, Ignition, and Spread in Tray Installations during Fire (CHRISTIFIRE), Phase 2: Vertical Shafts and Corridors,” issued in December 2013.

Future phases of CHRISTIFIRE are currently under development and include examining the effectiveness of various methods of protection for electrical cables.

SPENT FUEL SHIPPING CASKS SEAL PERFORMANCE UNDER BEYOND-DESIGN-BASIS FIRES

Small-scale fire tests were performed to evaluate the performance of spent nuclear fuel shipping cask seals during beyond-design-basis fires that exceed the manufacturers’ rated temperatures. The results of the first phase of testing were documented in NUREG/CR-7115, “Performance of Metal and Polymeric O-ring

Seals in Beyond-Design-Basis Temperature Excursions,” issued in April 2012.

The next phase will be small scale testing to further characterize different polymeric seal material and double O-ring seal configurations to investigate the effect of multiple seals in failure times and temperature exposures. This information will be used by NMSS to further develop risk insights related to the transportation of spent fuel.

HEAF TESTING

Experiments will be conducted to explore the basic configurations, failure modes and effects of HEAF (high energy arcing faults) events. The equipment to be tested consists primarily of switchgear and bussing components. The project will be conducted as part of a larger International OECD/NEA effort. RES will be leading the testing program for HEAF. Other international member countries participating in the project will provide equipment to be tested as well as technical expertise.

Fire & Electrical Systems Analysis

The experience from actual fire events confirms that damage to electrical cables may disable equipment and cause unexpected responses from instrumentation and control (I&C) signals. Realistic evaluation of fire-induced circuit damage, particularly involving spurious signals caused by “hot shorts,” is a very significant effort in fire risk assessments.

The Direct Current Electrical Shorting in Response to Exposure-Fire (DESIREE-FIRE) project extended the Cable Response to Live Fire (CAROLFIRE) test program (NUREG/CR-6931) to examine fire damage to direct current (DC) circuits. The DESIREE-FIRE test program involved a series of both small- and intermediate-scale fire tests. Each test exposed one or more electrical control cables commonly used in the existing fleet

of U.S. nuclear power plants (NPPs) to fire exposure conditions. Each test cable was connected to one of several circuit simulator units designed to mimic the behavior of typical NPP components. The simulated dc-powered control circuits included motor-operated valves, solenoid-operated valves of various sizes, and a medium voltage circuit breaker unit. Cable electrical performance is monitored throughout each test to determine both the timing and mode of circuit faulting behavior. The tests were performed in collaboration with EPRI under a Fire Research Memorandum of Understanding. The results were documented in NUREG/CR-7100, “Direct Current Electrical Shorting in Response to Exposure Fire (DESIREE-FIRE),” issued in April 2012.

An electrical circuit PIRT that examined the results from industry-sponsored cable tests and NRC-sponsored CAROLFIRE and DESIREE-FIRE was completed in October 2012. The results were published in NUREG/CR-7150, Volume 1, “Joint Assessment of Cable Damage and Quantification of Effects from Fire (JACQUE-FIRE).” The PIRT panel has identified some preliminary areas for future research. Those include evaluating the fire-induced effects on instrumentation circuits, electrical panel/cabinet wiring, surrogate ground path failure mode, current transformers, and high conductor count trunk cables. The results of the PIRT were also used to start a PRA expert elicitation to advance the state-of-the-art in understanding the probabilities of hot shorting. This work has been completed and its results will be published as Volume 2 of NUREG/CR-7150.

Fire Risk Assessment

Integration of fire risk into a full-scope PRA framework is an important research activity. The requirements of NFPA-805 and the guidance in NUREG/CR-6850, "EPRI/NRC-RES Fire PRA Methodology for Nuclear Power Facilities," provide cornerstones for the development of risk-informed, performance-based fire protection programs and a comprehensive assessment of fire risk.

A collaborative project with EPRI is evaluating elements of human reliability analysis (HRA) methods that apply to post-fire mitigation actions. The goal of this project is to recommend specific methods and guidance for the modeling and quantification of human errors during fire scenarios. Draft NUREG-1921, "EPRI/NRC-RES Fire Human Reliability Analysis Guidelines," was published in July 2012. The Office of Nuclear Reactor Regulation/Office of Nuclear Regulatory Research (NRR/RES), in partnership with EPRI, finalized NUREG-1934 (EPRI 1023259, "Nuclear Power Plant Fire Modeling Analysis Guidelines," in November 2012. Workshops on Basic Concepts of Fire Analysis, Basic Concepts of Human Reliability Analysis, and Basic Concepts of Nuclear Power Plant PRA were conducted in 2012.

Research is underway related to testing and evaluation of Very Early Warning Fire Detection (VEWFD) Systems. Research will enable assignment of value for such systems so that the specific values may be used in a fire PRA. The research effort will address testing, literature reviews, and site visits to support evaluation of this technology.

Fire Research Knowledge Management

Fire research continues to be a rapidly-evolving element of the RES mission. Compilation and dissemination of the information gained from this research, including new results and insights, is vital for understanding the current state of

knowledge and planned near-term advancements.

Relative to Knowledge Management, four excellent resources prepared by RES include:

- "The Browns Ferry Nuclear Plant Fire of 1975 and the History of NRC Fire Regulations," NUREG/BR-0361, January 2009. This DVD preserves the history of the Browns Ferry fire and documents its influence on the development of enhanced fire protection regulations. This work has been expanded and published as NUREG/KM-0002 in May 2013.
- "Fire Protection and Fire Research Knowledge Management Digest," NUREG/BR-0465, Revision 1, February 2009. This CD contains a compilation of fire-related reference materials that are useful for NRC inspectors, reviewers, licensees, and other stakeholders. It includes 10 CFR Part 50 ("Domestic Licensing of Production and Utilization Facilities"), guidelines for fire protection, fire inspection manuals and procedures, generic letters, bulletins, information notices, regulatory guides, and fire-related NUREG reports. This work has been updated and expanded and is in the process of being published as NUREG/KM-0003
- "A Short History of Fire Safety Research Sponsored by the U.S. Nuclear Regulatory Commission, 1975 – 2008," NUREG/BR-0364, June 2009. This report provides an historical perspective on NRC-sponsored fire safety research, summaries of current research activities,

and planned near-term research programs.

- “Methods for Applying Risk Analysis to Fire Scenarios (MARIAFIRES) 2008,” NUREG/CP-0194 July 2010. This report captures the 2008 NRC/EPRI joint training classes and provides a self-study program that can be viewed at the users’ convenience. In August 2013, NUREG/CP-0301 MARIAFIRES 2010 was published in two volumes. These two volumes expanded the training to include a volume on fire HRA and a separate volume on Course Prerequisites. Additional work is currently ongoing on updating and expanding the self-study training.

These references are updated periodically.

ASSESSMENT AND RECOMMENDATIONS

The NRC’s fire safety research program continues to make progress at the forefront of developing understanding of fire events and the assessment of risk from fire damage in nuclear power plants. Structured collaboration with industry provides cost-effective solutions and technical insights that surpass independent efforts. The NRC is a leader in national and international fire safety research.

The focus and priorities for current research projects are determined primarily by user-identified needs. This process is responsive to immediate and near-term technical issues. It should remain an important part of integrated planning. However, where identification of need is clear and beneficial, research priorities and programs should more actively anticipate additional emerging applications and potential intermediate- to long-term

requirements that are not fully dictated by current user needs.

Data and insights from the CAROLFIRE tests have considerably advanced the understanding of fire-induced cable damage. The results from the CHRISTI-FIRE and DESIREE-FIRE projects have also provided valuable input for assessment of risk from fires. CHRISTI-FIRE has been successful in providing basis for development of the FLASHCAT model to predict flame spread in horizontal tray configurations. The NRC should continue to encourage and support additional testing and fire experiments, and fire prediction model development, through collaborative efforts with U.S. industry and international organizations.

Guidance for the assessment of fire risk during low power and shutdown operating modes was completed in September 2013 and was published as NUREG/CR-7114, “A Framework for Low Power/Shutdown Fire PRA.”

As identified in NUREG/CR 6978, “A Phenomena Identification and Ranking Table (PIRT) Exercise for Nuclear Power Plant Fire Modeling Applications,” further research is recommended to evaluate performance of fire detection systems under complex geometries (e.g., highly congested spaces), performance of incipient detection systems, performance of fire sprinkler systems under highly obstructed conditions, and performance of fire sprinkler systems against a large oil pool fire.

New reactor designs rely heavily on integrated digital instrumentation, protection, and control systems. Extensions of operating licenses and obsolescence of analog equipment will likely lead to replacement of many currently installed I&C systems with digital platforms. Limited information is available regarding the effects from fire, heat, and smoke on digital equipment. To that end, based on “Joint Assessment of Cable Damage and

Quantification of Effects from Fire (JACQUE-FIRE)” additional research projects should be initiated that address issues related to instrumentation and control circuits and panel wiring.

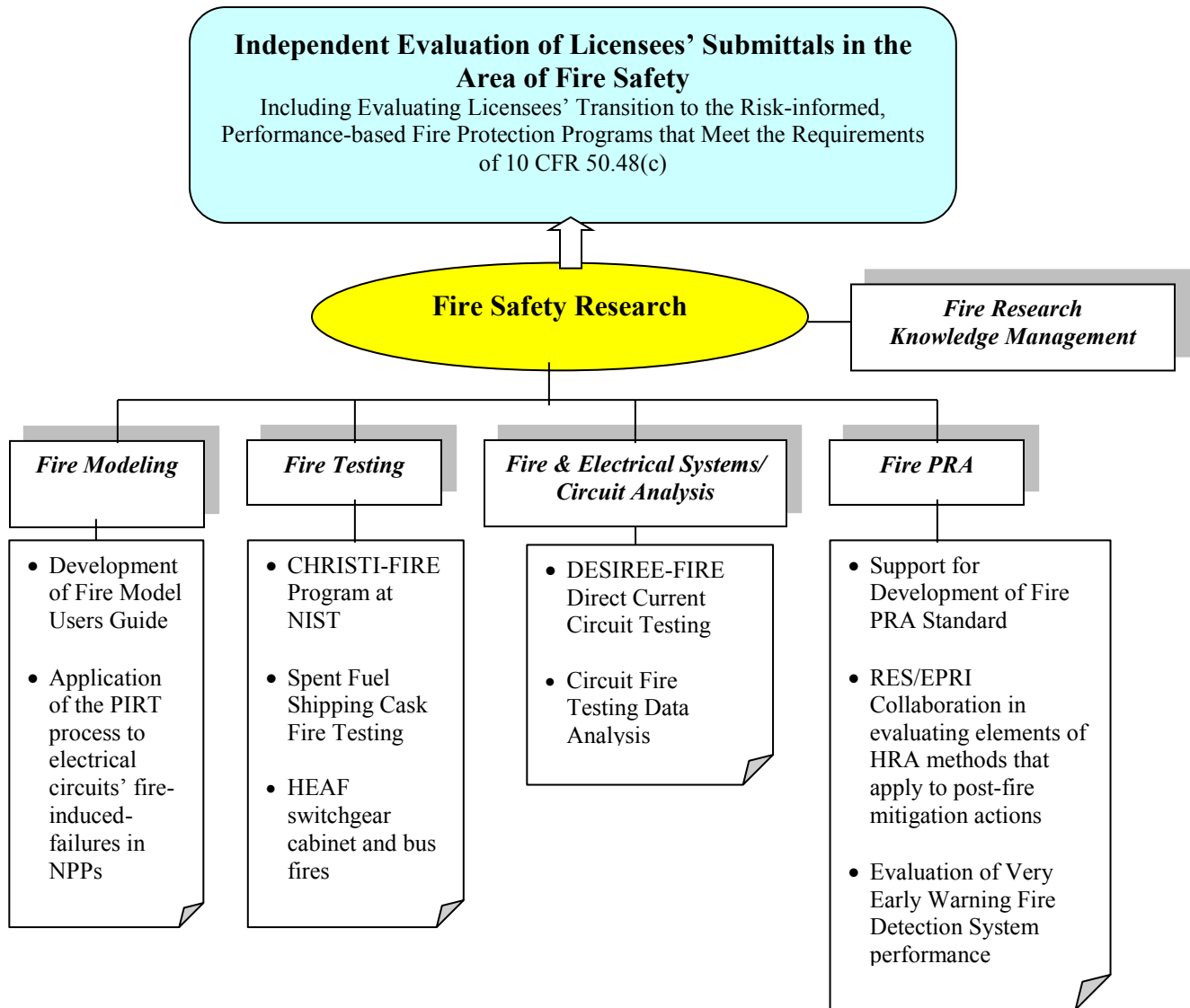

Figure 1. Current NRC Research Activities in Fire Safety

7. REACTOR FUEL

Background

Fuel integrity is an important contributor to nuclear plant safety. Fuel failures that may occur during normal operation or anticipated operational occurrences (AOOs) are not safety significant events because containment systems prevent release of radionuclides to the environment. Fuel failures, however, impact plant operation and economics. The various mechanisms capable of causing failures during normal operation have been identified, understood, and have been effectively controlled by fuel design, cladding materials, and operational improvements. The great majority of U.S. reactors operate without fuel failures.

Nuclear plant power uprates and higher fuel burnups, however, are steadily increasing the fraction of fuel operating near peak power levels, and the concentrations of fission products within the fuel rods. Concurrently, fuel cladding is being subjected to increased radiation damage, oxidation, and hydriding.

Manufacturers are addressing these more demanding requirements with fuel rod and assembly design changes, and with the introduction of new fuel pellet, cladding, and assembly structural materials. Lead use assemblies in which chemical additives are being used to improve fission gas retention and mechanical properties of the uranium dioxide (UO_2) fuel pellets have been licensed and are in operation. Similarly, new fuel cladding materials are in the development and regulatory pipeline. New cladding materials have been developed with improved corrosion and hydriding resistance during normal operation, and resistance to embrittlement during loss of coolant accidents (LOCAs). To a significant extent, these improvements have been made by industry as a result of findings from

the U.S. Nuclear Regulatory Commission's (NRC's) research.

NRC-sponsored research continues to focus on events in which fuel elements can fail and impact public health and safety. However, in view of fuel development trends, the NRC should maintain an adequate research program to assure its capability to evaluate and license future fuel designs. Continued participation in collaborative domestic and international research programs addressing the performance of new designs under normal conditions, AOOs, and severe accidents is essential in view of the limited U.S. nuclear test and examination facilities and declining research and development (R&D) budgets.

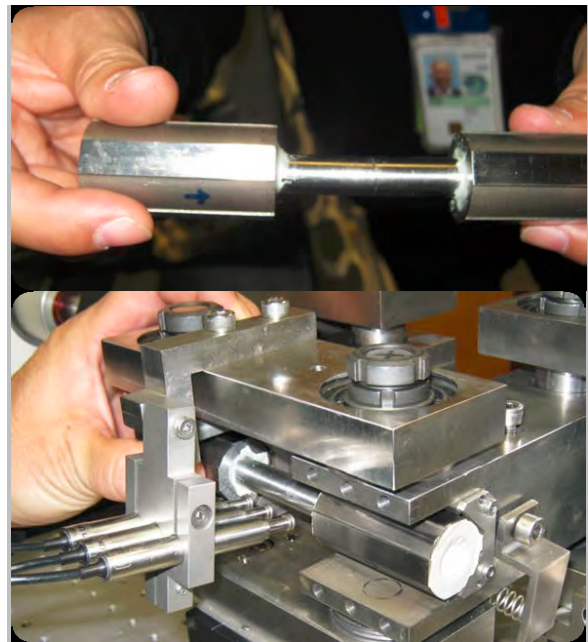

ORNL High Burnup Fuel Test Device

System utilizes electro-magnetic motors, a U-frame design, and a horizontal loading, enabling pure reversible bending. The grip sections induce uniform bending moment across the gauge sections

Current Research

Current NRC fuel research is addressing the properties of discharged fuel in response to Office of Nuclear material Safety and Safeguards (NMSS) user needs, and the performance of operating fuel in support of Office of Nuclear Reactor Regulation (NRR) user needs.

NMSS SUPPORT

High Burnup Spent Fuel Fatigue Testing for Transportation Applications

Research addressing spent fuel storage and transportation is being conducted at Oak Ridge National Laboratory hot cells. Mechanical tests of high-burnup (up to 65 gigawatt-days per metric ton (GWd/t)) fuel rods following extended storage under dry cask conditions are being performed to determine the extent to which slow degradation mechanisms (such as hydride reorientation) occurring during extended storage can affect fuel cladding static and cyclic properties. The stiffness, failure stress, and cyclic fatigue properties of irradiated fuel rod segments as well as unfueled cladding is being measured. The results of this research will provide an experimental basis for staff reviews of applications and amendments for dry-cask storage and transportation of spent high burnup fuel. A novel test apparatus was designed and qualified for these difficult measurements (see sidebar on page 31). Calibration and benchmarking has been completed and testing of irradiated fuel is in progress.

Consequence Assessment of Fuel Failure on the Safety of Spent Nuclear Fuel Dry Storage and Transportation Packages

The consequence assessment has been completed and a NUREG documenting the impact of a range of postulated (damaged or failed) fuel configurations on criticality, dose rates, containment, and fuel

temperatures in transportation and storage packages is under review. Although the study has evaluated a wide range of physically realizable scenarios, additional work may be needed to evaluate the likelihood of the scenarios and configurations.

Extended Storage of High Burnup Fuel: Cladding Stress Analysis

Mechanisms that may affect fuel cladding stress and mechanical properties during extended dry storage are being evaluated to determine whether they are sufficient to cause a cladding failure concern. Proposed sources of stress are plenum gas pressure buildup, phase changes and reorientation of the hydrides upon cooling from drying temperatures, and swelling of the fuel due to a buildup of helium decay products. This research has established that gas generation resulting from the decay of fission products is not sufficient to increase the rod internal pressure, even if 100 percent of the decay gases are released to the rod voids volume. This research has also established that fuel lattice swelling saturates at about 1 displacement per atom (dpa) at values in the range of ~0.3 and ~0.45 percent. Although spent fuel will accumulate between 0.1 and 5 dpa over a period of 100 years of storage, saturation effects will limit increases on cladding stress. These values are now being incorporated into a modified version of the FRAPCON fuel performance code to determine cladding stress and creep rates during extended exposure. Experimental work has been completed at Argonne National Laboratory to develop an approach to determine the effects of zirconium hydride dissolution and reorientation during cask loading and drying on the ductility of spent fuel cladding. This work has yielded definitive results by demonstrating that a new metric (the radial-hydride continuity factor) of irradiated cladding correlates well with the measured ductile-to-brittle transition temperature (DBTT) measured by the ring compression

test. Additional work using this approach is being pursued under U.S. Department of Energy (DOE) sponsorship.

NRR SUPPORT

The Studsvik Cladding Integrity Program (SCIP)

The NRC has participated in the internationally sponsored SCIP program for several years. The program has completed experimental and analytical research on the pellet cladding interaction (PCI) fuel failure phenomenon. The SCIP 1 and 2 programs have amassed an impressive database including 1,119 power ramp tests (800 boiling-water reactors (BWR), 213 pressurized-water reactors (PWR), 81 pressurized heavy water reactors (PHWR), and 25 unspecified), as well as separate effects testing and modeling. Although limited work will continue on PCI, the SCIP research program will focus on the phenomenon of fuel fragmentation, axial relocation, and fuel dispersal from high burnup fuel following loss of coolant accidents (LOCA). The program will include:

- Fuel rod testing at Halden and Studsvik
- Out-of-pile integral LOCA testing and separate effects testing to determine the fine fuel fragmentation burnup threshold, parameters influencing fine fragmentation, and the cladding strain threshold for fuel axial mobility
- Separate effects testing to investigate role of fuel microstructure on fragmentation, the effects of cladding overheating on post AOO cladding properties, and the effects of axial load on cladding failure

Fuel Fragmentation, Relocation, and Dispersal Research

NRC research was directed to determine the conditions that result in fuel fragmentation, relocation, and dispersal; the amount of fuel dispersed and its impact on post-LOCA fuel coolability; and then to recommend appropriate regulatory actions. Experimental and analytical work completed to date shows good progress in addressing the above questions. Available data has been incorporated into a new approach to core-wide LOCA modeling aimed at the prediction of fuel dispersal. Using steady state and transient fuel performance (FRAPCON & FRAPTRAN) and system thermal hydraulics (TRACE) codes, the likelihood and amount of fuel dispersal for a small set of BWRs and PWRs has been determined.

Fuel Performance Codes FRAPCON and FRAPTRAN

A number of significant improvements have been made to the NRC's fuel performance codes. For example, FRAPCON-3.5 to be released early in 2014 includes: updated cladding creep hydrogen pickup models, variable axial nodes and zoning for enrichment, Gadolinia, and annular pellets, expanded arrays for increased number of nodes and time steps, treatment of pellet chamfers, correlations for fuel-specific heat, and high stress cladding creep. Similarly FRAPTRAN-1.5 to be released early in 2014 includes: expanded arrays for increased number of nodes and time steps, treatment of pellet chamfers, advanced LOCA modeling (external plenum, double sided oxidation, thermal-hydraulic improvements), and clad ballooning models. In addition, research has provided statistical tools (ARM FRAPTRAN and ARM FRAPCON) which are widely used by NRR. Future improvements in the capabilities of these codes are in progress with the planned introductions of FRAPCON 4.0 and FRAPTRAN 2.0 in 2016.

Accident Tolerant Fuel (ATF)

In response to events at Fukushima, an ATF development program is being implemented as a collaborative effort among national laboratories, industry, and universities within the United States. Fuels with enhanced accident tolerance are those that, in comparison with the standard uranium dioxide—zirconium ($UO_2 - Zr$) system, can tolerate loss of active cooling in the core for a considerably longer time period (depending on the light-water reactor (LWR) system and accident scenario) while maintaining or improving the fuel performance during normal operations. A wide variety of unconventional fuel and cladding materials and fuel designs are being evaluated for ATF development. Currently, the NRC is monitoring DOE and industry activities related to the development program. A down selection of the most promising ATF concept or concepts is scheduled for 2016, and at that time the NRC may need to engage in regulatory research. As the program makes progress, there will be a need for NRC engagement in the development of an ATF licensing strategy. This is a long-term program, and initial insertion of lead test assemblies into commercial reactors is not scheduled until 2022.

Assessment and Recommendations

NMSS Support

Current research in support of spent fuel storage and transportation issues is well structured and making excellent progress.

NRR Support

Current research addressing fuel fragmentation, axial relocation, and dispersal is very well structured, has made excellent progress, and is well on its way to generating experimental and analytical results to support regulatory decisions. In contrast, the very large BWR and PWR experimental PCI database assembled under the SCIP program should be incorporated into the NRC fuel performance codes or the Standard Review Plan.

The FRAPCON and FRAPTRAN fuel performance codes meet most near-term agency needs. There is ample capability to assess risks of fuel failure due to fuel center melting, excessive mechanical strain, and departure from nucleate boiling events. However, the NRC is still developing capability to quantitatively assess the more likely risk of PCI fuel failures during AOOs for current or future fuel designs. This topic is also important to consider if load following is to be considered in future LWR operation.

Advances in computing power and computational simulation are making it possible to examine fuel performance in vastly more detail than is done with either FRAPCON or FRAPTRAN. Whether such detail is needed will depend critically on what efforts are made by licensees to extend fuel burnups beyond the current regulatory limit of 62 GWd/t and the amount of experimental data provided to support these proposed changes to regulatory limits. Consequently, there will be a continuing need for the agency to independently evaluate the safety of proposed changes in the nature and burnup limits of reactor fuels.

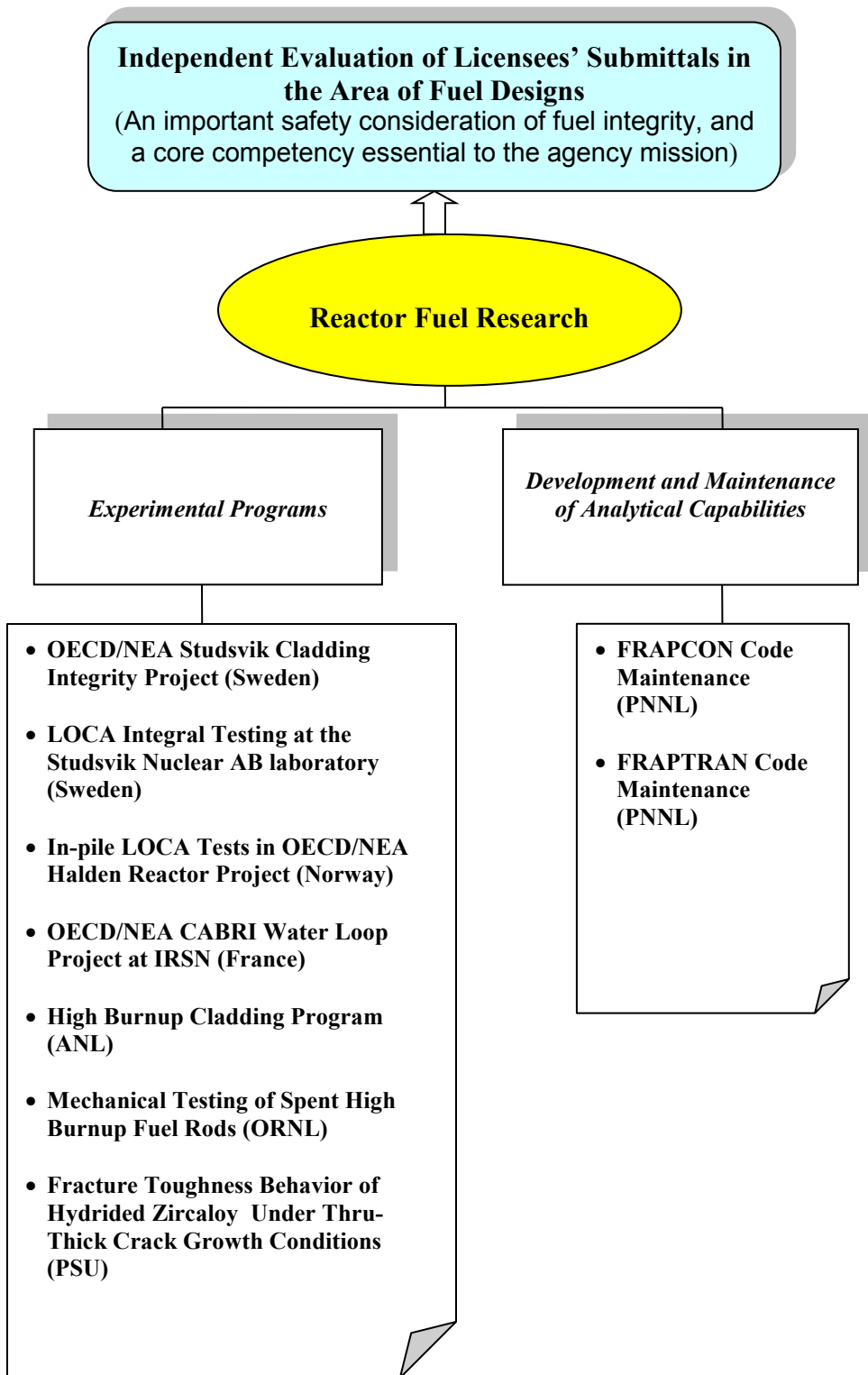

Figure 2. Current NRC Research Activities in Reactor Fuel

8. HUMAN FACTORS AND HUMAN RELIABILITY

All nuclear facilities and activities involve human operators and maintenance personnel. Understanding how people interact with machines is necessary to ensure safe operations. The staff's research activities are focused on improving the NRC's understanding of the issues affecting human performance and developing tools for analyzing performance, as well as developing systems to improve the operating environment to enhance the opportunities for improving performance.

Research funding continues to be primarily associated with user needs requests from the Office of Nuclear Reactor Regulation (NRR), Office of New Reactors (NRO), and Office of Nuclear Material Safety and Safeguards (NMSS). To be successful in meeting long-term research needs, the Office of Nuclear Regulatory Research (RES) staffs work with counterparts in those organizations to craft projects that meet both current and future needs.

Current Research Activities

The Human Factors and Reliability Branch has adopted a goal-oriented framework to organize its research program. The four program goals are as follows:

- (1) Maintain the infrastructure of expertise, facilities, capabilities, and data.
- (2) Ensure that Human Factors (HF)/Human Reliability Assessment (HRA) methods and programs have sound, up-to-date technical bases and guidance.
- (3) Improve HF/HRA methods to reduce uncertainty and promote the state-of-the-art.



The NRC Human Performance Simulation Facility at the University of Central Florida

- (4) Expand the HF/HRA infrastructure for new applications (anticipated changes in industry).

Figure 3 shows the program goals and lists major research topics in each area. Highlights of these programs are provided below.

Advanced Control Room Human Factors

New nuclear power plants (NPPs) will differ from the current plants in several ways that will change how operators interact with the plant: many employ passive designs, all will employ extensive use of digital instrumentation and control (DI&C) systems, and new human-system interfaces will be used. The staff convened a group of experts from research organizations, vendors, and utilities to prioritize research needs. NUREG/CR-6947, "Human Factors Considerations with Respect to Emerging Technology in Nuclear Power Plants," provided the results of this process, which led to a number of follow-on research projects to support advanced control room designs.

These programs are examining whether new computerized procedures can provide adequate safety; developing measurement tools to evaluate workload, situational awareness, and teamwork; developing qualitative operator models to predict operator performance and errors; and developing a technical basis for regulatory decisionmaking regarding safety culture. All these projects have the potential to improve operator performance and provide clear bases for regulation.

At the juncture of HF and HRA, the RES has procured two desktop computer based NPP control room simulators (one housed at NRC headquarters and the other at the University of Central Florida) and is developing a human performance test facility. These facilities will allow the staff to perform experiments rather than relying solely on collaboration in contracted facilities.

Support for Fukushima-related Initiatives

The reactor accidents resulting from the earthquake and tsunami at Fukushima in Japan and the observed and inferred activities by operators at the Dai-ichi plants have led to HF/HRA research in several areas. The feasibility and reliability of human actions in re-evaluated flooding events is being studied. Guidance is being developed for evaluating human performance implications of filtered vents. RES is also supporting the onsite emergency response capabilities rulemaking.

Fitness-for-Duty Support

This ongoing effort provides scientific and technical support to four concurrent rulemakings, support to update Regulatory Guide 5.73 ("Fatigue Management for Nuclear Power Plant Personnel"), support to Title 10 of the *Code of Federal Regulations* (10 CFR) Part 26 ("Fitness for Duty Programs") implementation, and evaluation

of the feasibility of performance indicators for fitness-for-duty programs.

Safety Culture Enforcement and Policy Statement Implementation

This ongoing effort provides support for safety culture inspections and support for assessment of the Safety Culture Policy Statement implementation.

Human Reliability Analysis

Since the earliest days of probabilistic risk assessment (PRA), researchers and practitioners have sought methods for the analysis of human performance during accident scenarios that offer face validity and clearly demonstrable accuracy. The result has been a proliferation of methods, none completely satisfying to all interested parties.

The need for resolution was recognized by the Commission in a November 8, 2006, staff requirements memorandum (SRM) directing the Advisory Committee on Reactor Safeguards (ACRS) to "work with the staff and external stakeholders to evaluate the different Human Reliability models in an effort to propose either a single model for the agency to use or guidance on which model(s) should be used in specific circumstances." In response, the staff initiated a series of research projects. The International HRA Empirical Study used the Halden Man-Machine Laboratory (HAMMLAB) to simulate accident sequences. It is a multinational, multi-team effort co-sponsored by the OECD Halden Reactor Project, the Swiss Federal Nuclear Safety Inspectorate, and the Electric Power Research Institute (EPRI). The objectives were to collect and analyze crew performance data, to separately apply HRA models to predict crew performance, and to evaluate these models on the basis of a comparison of the simulator data with the model predictions. Following a pilot study and a follow-on study, the staff organized a

U.S. HRA Empirical Study, again using the expertise of HAMMLAB personnel, in a series of experiments run at a U.S. nuclear power plant.

The results of the three sets of experiments have been examined by an international group that developed a number of summary conclusions and a strong recommendation that all HRA analysts develop first a solid and thoroughly documented qualitative analysis to guide later quantification. The NRC staff has used these conclusions and recommendations as the starting point for developing a hybrid HRA method, borrowing the best aspects of other methods applied during the three empirical studies. The goal is to have a single method, or a limited set of alternative methods with a common qualitative underpinning, to apply to specific HRA problems.

Because of fixed schedule demands, the staff has performed parallel specific HRA methods development activities for NPP fires, fuel cask handling, low power/shutdown conditions, and medical treatments. Participants in these programs have been aware of the SRM-directed activity to develop a single methodology, so we hope that they can all be brought together, once the SRM-driven approach is refined and tested.

Assessment and Recommendations

The staff's participation in domestic and international collaborations strengthens the human factors/human reliability research activities and should be encouraged. These collaborations have included Organization for Economic Cooperation and Development, EPRI, National Aeronautics and Space Administration, and professional organizations (e.g., American Nuclear Society, IEEE, and American Institute of Chemical Engineers). The staff has

arranged for international experts to be involved in many of their research efforts.

The HF/HRA research program has evolved into a carefully coordinated series of projects that are extending knowledge and providing useful products to regulators. The Integrated Decision-tree Human Event Analysis System (IDHEAS) HRA methodology program has integrated experience from the International and U.S. HRA empirical studies to identify positive and negative aspects of existing HRA methods and developed a hybrid approach. The project has produced three reports: a very helpful volume on the cognitive foundation for HRA, a generic HRA methodology document, and an evolving IDHEAS method for internal events at power. The methodology needs to be tested on a large-scale application to ensure that it is practical. The guidance must be improved, especially to strengthen the qualitative analysis.

In discussions with staff from the Human Factors and Reliability Branch, we found that three areas could benefit from increased emphasis in the future: the work on medical applications should receive more emphasis, the development of HRA and HF approaches to support the Office of Nuclear Security and Incident Response (NSIR) applications needs to be explored, and the work on the effects of degraded I&C systems on human performance should be expanded.

Finally, as the forensic efforts at Fukushima produce new understanding of severe accidents at boiling-water reactors (BWRs), new research into ways to provide improved support to operators during such accidents will be needed.

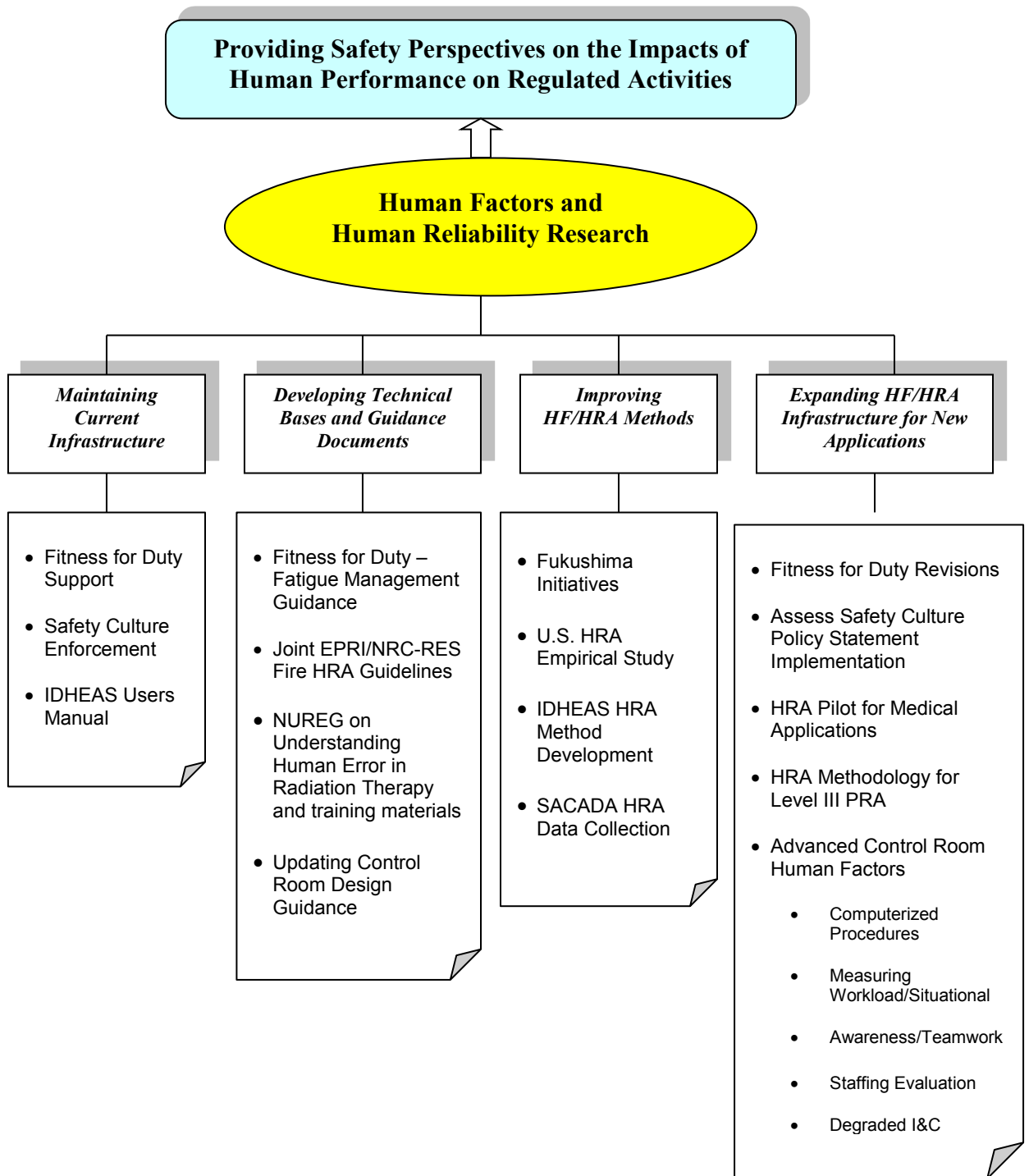

Figure 3. Current NRC Research Activities in Human Factors and Human Reliability

9. MATERIALS AND METALLURGY

Background

There are 100 power reactors operating in the United States. While originally licensed for 40 years, all of the reactors that have not been shut down for economic or other reasons have applied for a license extension to 60 years. The continued increase in reliability, coupled with replacement of most large components (steam generators, pressurizers, etc.) and power uprates has demonstrated the value of existing plants. Improved knowledge of the aging mechanisms in play coupled with improved modeling and simulation methods has led to the realization that operating the existing plants beyond the license renewal period of 60 years is possible. However, operating beyond 60 years, termed "Subsequent License Renewal," will require careful investigation of the potential for current degradation phenomena, or new phenomena that have not manifest themselves, to cause a decrease in reliability and safety.

Materials and metallurgy continues to be an active area of research within the U.S. Nuclear Regulatory Commission (NRC). This is appropriate in light of the efforts required by the agency to address known and emerging materials degradation phenomena in aging light-water reactors (LWRs), and to monitor the effectiveness of licensees' aging management programs. Due to the importance of long-term operation (license renewal and subsequent license renewal), it is critical that the NRC safety research programs in materials and metallurgy not only be following—and supplementing where necessary for safety—current issues related to environmental degradation, but also be forward looking to stay ahead of major issues that may be anticipated to be important for long-term operation.

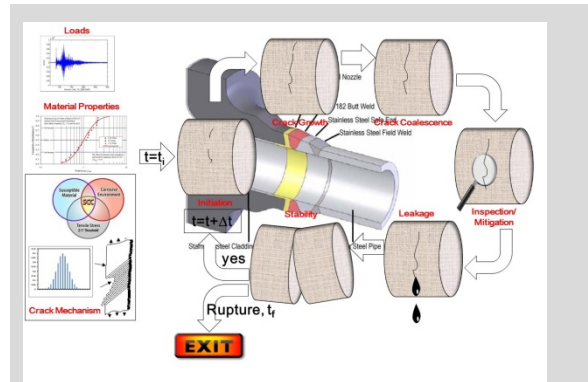

Extremely Low Probability of Rupture (xLPR) Project

The NRC has initiated a multi-task cooperative research project (xLPR) with industry that will produce a flexible, modular, state-of-the-art probabilistic fracture mechanics code that can be used to assess the risk of pressure boundary rupture.

Current Research Activities

The materials and metallurgy research efforts are conducted by the Component Integrity Branch and the Corrosion and Metallurgy Branch within the Division of Engineering of the Office of Nuclear Regulatory Research (RES). Topical areas of research can be grouped into five broad categories:

- (1) proactive management of materials degradation
 - (2) component integrity assessment
 - (3) non-destructive examination (NDE)
 - (4) environmentally assisted cracking (EAC)
 - (5) steam generator related research
- RES continues to make excellent use of domestic and international cooperative

programs to accelerate progress, reduce cost, and resolve key issues related to the detection, understanding, and mitigation of materials degradation phenomena.

Proactive Management of Materials Degradation

The nuclear industry and the NRC have often been surprised by unexpected materials degradation events. Unexpected materials degradation in nuclear power plants has led to a heightened interest by the NRC and nuclear power industry in developing a proactive approach to materials degradation management. The NRC initiated the project “Proactive Materials Degradation Assessment” (PMDA) to identify materials and systems in LWRs where degradation can reasonably be expected to occur in the future. With such knowledge, the inspection and monitoring programs at plants could be reviewed and modified as needed to provide early identification of incipient degradation. A comprehensive assessment of the likelihood and safety significance of possible environmental degradation mechanisms for approximately 1,900 boiling-water reactor (BWR) and pressurized-water reactor (PWR) components was completed in 2008. The results of this effort have been documented in NUREG/CR-6923, “Expert Panel Report on Proactive Materials Degradation Assessment.”

The Advisory Committee on Reactor Safeguards (ACRS) supported the initial vision of the proactive materials degradation assessment (PMDA) project and the later expansion of its original scope to include concrete structures and electrical cable insulation. The NRC, in collaboration with the U.S. Department of Energy (DOE), has undertaken an expansion of the scope originally investigated in NUREG/CR-6923 to identify any additional degradation phenomena that must be considered for extension of operation beyond 60 years. The results of this effort are being

documented in a five-volume NUREG/CR-7153, “Expanded Materials Degradation Assessment” (EMDA). The analyses have focused on the following areas: (1) core internals and piping systems, (2) reactor pressure vessel steels, (3) concrete civil structures, and (4) electrical power and instrumentation and control cabling and insulation.

The EMDA process has resulted in:

- Determining the status of the current knowledge base and updating the PMDA-developed information.
- Identifying gaps in knowledge for systems, structures, and components (SSC) or materials that warrant future research.
- Identifying potential new forms of degradation.
- Identifying and prioritizing the research needs.

Assessment: The program has identified key areas of concern for subsequent license renewal operation (time frames of 60-80 years). The current research programs will likely be adequate to address most areas of concern. There is one area that is not currently being addressed that should be further evaluated. There is recent research that indicates that the exposure of stainless steels and nickel-based alloys to high-temperature water in the absence of radiation damage can result in a significant decrease in tearing resistance and fracture toughness. If confirmed, this effect, in combination with radiation-induced toughness reduction, may become a safety issue in the future.

COMPONENT INTEGRITY ASSESSMENT

The topical areas of research within the component integrity assessment addresses the development of a probabilistic fracture

mechanics tool (xLPR), the integrity of dissimilar metal welds, and reactor pressure vessel (RPV) integrity. In addition to research on metallic components, work is also being done to confirm the acceptability of high-density polyethylene (HDPE) piping for long-term safety-related applications.

Development of the xLPR code: General Design Criterion 4 (GDC-4), “Environmental and Dynamic Effects Design Bases,” of the Appendix A to Title 10 of the *Code of Federal Regulations* (10 CFR) Part 50, “General Design Criteria for Nuclear Power Plants,” allows local dynamic effects of pipe ruptures to be excluded from the design basis if it is demonstrated that the probability of fluid system piping rupture is extremely low under conditions consistent with the design basis. Leak before break (LBB) must be assured. However, if EAC is present, there is the possibility that for some conditions these requirements may not be met. The purpose of the xLPR program, a cooperative effort between the NRC and industry, is to develop the methodology which, when combined with inspection, will assure that these criteria will be met. The xLPR program has developed a probabilistic framework for the assessment of LBB issues in primary system SSCs. Although initially focused on resolving the primary water stress-corrosion cracking (PWSCC) challenge for PWRs, the intent of the extremely low probability of rupture (xLPR) project is to develop a fully probabilistic approach applicable to a range of active degradation mechanisms associated with both BWRs and PWRs.

Assessment: The xLPR program is developing a quantified, fully quality assurance (QA) certified, solution to the LBB issue. It represents the state-of-the-art in probabilistic fracture mechanics. Use of xLPR will allow for assessment of component life for current, extended, and subsequent license renewal periods. The program is meeting and exceeding its goals.

Reactor Pressure Vessel Integrity:

Reactor pressure vessel embrittlement has been identified as a potential life-limiting issue for operating in the 60-80 year time frame. As such, it is important that the NRC safety research program supports the evaluation of pressure vessel embrittlement as the plant ages.

The reactor pressure vessel integrity research has led to revision of several NRC regulations, such as the pressurized thermal shock rule in 10 CFR 50.61, “Fracture Toughness Requirements for Protection against Pressurized Thermal Shock events,” and 10 CFR 50.61a, “Alternate Fracture Toughness Requirements for Protection against Pressurized Thermal Shock Events,” as well as related American Society of Mechanical Engineers (ASME) and American Society for Testing and Materials (ASTM) codes and standards. Work is now in progress to revise other rules that address pressure vessel integrity such as Appendix G, “Fracture Toughness Requirements,” and Appendix H, “Reactor Vessel Material Surveillance Program Requirements,” to 10 CFR Part 50.

The NRC is also sponsoring the Reactor Embrittlement Archive Project (REAP) at the Oak Ridge National Laboratory (ORNL) to create a Web-based RPV steel embrittlement archive database for the entire U.S. fleet of 104 commercial NPPs. The REAP project is intended to provide an important tool for reactor pressure vessel (RPV) integrity assessment within the NRC regulatory environment.

Assessment: The RPV integrity programs, as currently structured, are meeting goals. However, these programs will need to be reassessed in light of the recommendation that will come from the EMDA analysis.

HDPE: HDPE piping has been used for more than 10 years in nonsafety-related service water piping in nuclear power plants. HDPE piping has very attractive

characteristics in the areas of corrosion and ease of installation/fabrication. Special exemptions have been applied for and granted for use in selected safety-related applications, but this has been rare due to issues related to joining, the inspection of “welded” joints, and aging-related phenomena that are not fully understood. ASME Code Case N-755-1, “Use of Polyethylene (PE) Class 3 Plastic Pipe Section III, Division I and Section XI” describes the requirements for use of HDPE in Class 3 buried pipe systems. The current NRC research programs are being conducted in collaboration with EPRI and with the Nuclear Energy Standards Coordination Collaborative (NESCC). The goals of these programs are to confirm the proposed requirements for use in ASME Class 3 safety-related applications and to support the Office of Nuclear Reactor Regulation (NRR) and the Office of New Reactors (NRO) in ASME code actions and relief requests. Confirmatory research is also being conducted related to fusion joint integrity and nondestructive evaluation (NDE) methods.

Assessment: The level of effort in this area is appropriate for the need. HDPE will see much more extensive use in the future as service water and other related systems are repaired or replaced. The maintaining of joint integrity and verification by NDE methods are the key issues for their use in safety-related systems.

Non-destructive Examination

Improvement of NDE resolution and sensitivity will be of increasing importance for extended operation where margins may be reduced. There are currently three ongoing research programs: (1) Effectiveness and Reliability of NDE for Vessels and Piping; (2) Evaluation of Ultrasonic Testing (UT) in Lieu of Radiological Testing (RT) for Repairs and Modifications; and (3) Program to Assess Reliability of Emerging Nondestructive

Techniques (PARENT).

The project “Effectiveness and Reliability of NDE for Vessels and Piping” is a renewal of a previous program of the same name. As plants age and the possibility that heretofore unknown degradation mechanisms may manifest themselves, it will be critical that more accurate and detailed characterization of degradation be achieved. The industry, through EPRI, has made significant strides in the development of new techniques and application of these techniques to areas where previous techniques have been inaccurate. This is especially true for welds where stress corrosion cracking (SCC) is an active degradation mechanism. It is important that the NRC maintain competence in this area and maintain the expertise to evaluate new techniques.

The project “Assessment of Reliability of Emerging NDE Techniques” is a compliment to the effectiveness and reliability project above. The project focuses on the reliability of inservice inspection (ISI) techniques for degraded welds. A cooperative agreement between the NRC and the French IRSN is being implemented to develop techniques for inspection of coarse grained materials in dissimilar metal welds.

An additional research project is underway to evaluate the use of phased array UT to detect PWSCC leakage between the reactor upper head penetration and the reactor pressure vessel head such as has occurred at the North Anna nuclear power station. The leakage path was detected by UT and confirmed by destructive examination of the nozzle. In addition, the pattern of boric acid deposits observed with phased array UT was in agreement with observation during destructive examination at North Anna.

Assessment: Accurate NDE methods are critical to assurance of system integrity and complement the probabilistic fracture mechanics methods development in the

xLPR program. New NDE techniques promise to reduce the uncertainty in characterization of defects, which will improve the results of component life evaluation. This will be especially important for operation beyond 40 years. The current programs will keep the staff current in the latest developments. These programs are meeting their goals.

Environmentally Assisted Cracking

Environmentally assisted cracking is a generic term for the various stress corrosion cracking mechanisms that can be active in BWRs and PWRs. These complex phenomena are influenced by applied and residual stresses, water chemistry, radiation exposure, temperature, material composition, microstructure, and fabrication history. The topical areas of research within the environmentally assisted cracking (EAC) umbrella include irradiation assisted degradation, primary water stress corrosion cracking (PWSCC), environmental fatigue, spent fuel storage system degradation, containment liner corrosion, and used fuel neutron absorber issues.

Irradiation Assisted Degradation /PWSCC: As has been discussed above, SCC is the dominant degradation mode for pressure boundary and structural materials in the primary system. The addition of the radiation environment aggravates the situation by causing radiation hardening, a reduction in ductility and toughness, and radiation induced segregation (RIS) that increases susceptibility to PWSCC. In addition, for cast materials there is the potential for a combination of thermal aging and neutron exposure to reduce toughness in these materials. Radiation effects, including hardening and swelling, are also an issue for extended operation beyond 40 years. However, it is believed that this phenomenon is adequately understood and, as such, will not likely be an issue for extended operation. Research programs in this area include the study of: (a) cracking

of stainless steels in low corrosion potential (e.g., PWR) environments, (b) the effect of irradiation on void swelling-material exposed in the BOR-60 reactor, and (c) crack growth and fracture toughness of irradiated case stainless steel. Most of these programs have recently terminated. The key results of these programs include the following:

- (1) In low potential environments (PWR) both cold worked and non-cold worked stainless steels exhibit increasing SCC crack growth rates with increasing fluence from 5 to 25 displacements per atom (dpa).
- (2) Fracture toughness of the same materials decreases with increasing fluence up to 8 dpa with toughness J values at crack initiation below 100 kJ/m².
- (3) For cast stainless steel that has been thermally aged, low dose (0.08 dpa) decreased the fracture toughness in addition to the decrease from thermal aging alone.

In addition to the program on stainless steels, a research project is underway on PWSCC of nickel-based alloys. The purpose of this project is to help in the development of a safety evaluation criteria for this material when used as pressure boundary. The focus has been on Alloy 690 and its weld metals (Alloy 52 and 152) compared to Alloy 600 and its weld metals (Alloy 82 and 182). The results have shown that Alloy 690 is very resistant to PWSCC unless subjected to significant cold work. The results have also shown that dissimilar weld dilution zones may be susceptible to PWSCC.

Assessment: PWSCC is the dominant degradation mechanism for the primary pressure boundary. While replacement components will be fabricated with more resistant materials using Alloy 690 and its

weld metals, this form of degradation will continue to be an important issue especially for extended operation. It is thus very important that the staff maintains expertise in this area and that the NRC participates in research in this area. Research in PWSCC, via collaboration or partnering with industry, should continue. The international community has established a collaborative body that is now called the International Cooperative Group on Environmentally Assisted Cracking (ICG-EAC). It has been in operation for several decades and was co-founded by the NRC. The group meets once a year and brings together the world's experts in this area. The NRC is currently a member and should remain so.

Environmental Fatigue: Environmental fatigue has been identified as a potential issue for extended operation (EMDA). Research in this area includes updates to the existing environmental fatigue evaluation methodology as outlined in Regulatory Guide 1.207, "Guidelines for Evaluating Fatigue Analyses Incorporating the Life Reduction of Metal Components Due to the Effects of the Light-Water Reactor Environment for New Reactors," and NUREG/CR-6909, "Effect of LWR Coolant Environment on the Fatigue Life of Reactor Materials."

Assessment: The level of effort in this area is appropriate for the need.

Spent Fuel Storage Systems

Degradation: The dry storage canister systems in use today were designed with the expectation that within approximately 20 years the spent fuel would be transferred to a permanent storage facility. Materials choices were made with this assumption. Conventional austenitic stainless steel (almost exclusively Type 304) was selected as the pressure boundary material. However, with the new requirements that dry storage systems be available for time periods greater than 80 years, the materials choice has now been demonstrated to have been a poor one. Painful experience has shown that the use of this material in a chloride-containing environment can be problematic if great care is not taken to eliminate tensile stresses. Moreover, for exposure in salt environments, salt deliquescence can take place at temperatures in the 50-60°C range and humidity values that are normally present. Chloride concentrations in the thousands of parts per million (ppm) are easily achievable. This chemistry, in combination with non-stress relieved welds, will eventually result in SCC of this material. The realization that the reliability of dry cask storage systems will be a concern has prompted the development of a number of research programs that are being conducted in collaboration with DOE. These include: (a) SCC of Dry Storage Canisters, (b) Vacuum Drying of Spent Fuel Canisters, and (c) Functional Monitoring of Dry Cask Storage Systems.

The results of this research have confirmed that for environments that can easily be achieved with canisters at sites where salt can deposit on the material, SCC will occur. The overall conclusions of the chloride-exposure research are as follows:

- (1) For simulated sea salt, SCC on Type 304 stainless steel is possible and has been observed between 35 and 80°C when the relative humidity is higher than 20-30 percent.
- (2) SCC initiation has been observed at salt quantities as low as 0.1 g/m² or a metal strain as low as 0.4 percent. The extent of cracking increases with increasing salt quantity or strain.
- (3) Sensitized material is more susceptible to SCC than material in the as-received (non-sensitized) condition.
- (4) No SCC was observed for material exposed to non-chloride bearing species.

In addition to SCC-related research, there are programs that address vacuum drying and monitoring of canisters.

Assessment: Much of the research in this area is being conducted by DOE as a part of Nuclear Energy University Programs (NEUP). These include modeling of canister life, drying and development of monitoring systems. The NRC staff is also participating in the industry sponsored Extended Storage Collaboration Program (ESCP) that is the umbrella for research in this area. The direct NRC funded research in this area is making a significant contribution to the knowledge base and should be continued. Close monitoring of the non-NRC funded programs should be maintained and additional research conducted if significant gaps are observed.

Containment Liner Corrosion:

Containment liner corrosion has occurred in cases where unique conditions have been present. Corrosion is almost exclusively from the outside when a foreign object (piece of wood, etc.) has been left in contact with the steel liner during construction. Perforation of the containment can result in leakage during a design-basis loss of

coolant accident. The purpose of this research is to determine if additional inspections should be required in accordance with ASME Section XI, Subsection IWE. The conclusions of this research include the following:

- (1) The corrosion cell that can be developed will support a high corrosion rate and a significant corroding area.
- (2) Through wall corrosion is initiated from foreign objects left in the concrete during construction.
- (3) The leak rate is controlled by the size of the hole in the containment when the hole is small (~ 10 mm²).
- (4) Radioisotope releases would be largely restricted by the narrow gap between the liner and the containment wall.

Assessment: The level of effort in this area is appropriate for the need.

Neutron Absorber Degradation: Neutron absorber is used in the spent fuel pool to allow for higher density racking and prevent criticality. The boron is imbedded in either a metal or phenolic resin based material. Degradation of the materials results in a loss of boron from these materials. Additionally, modeling of this degradation has been difficult with a lack of correlation between experiment and model results in many cases. The research programs in this area are designed to determine if future regulatory actions are needed.

Assessment: The level of effort in this area is appropriate for the need.

Steam Generator Related Research

Stress corrosion cracking has been problematic for steam generators with mill annealed Alloy 600 tubing. While thermally treated Alloy 600 tubed steam generators have experienced minimal SCC, the

consensus is that these steam generators will eventually experience SCC as well. Operation beyond the 40 year initial license period adds additional concern that tube degradation in Alloy 600 tubed steam generators will continue to be an issue. Essentially all of the original mill annealed Alloy 600 tubed steam generators have been replaced with either thermally treated Alloy 600 or Alloy 690 tubed units. Alloy 690 has been shown to be extremely resistant to SCC and no instance of SCC in these units has been reported to this date. However, as the degradation due to excessive wear in the San Onofre steam generators has demonstrated, although due to excessive thermo-elastic vibration, the performance of steam generator tubing must continue to be monitored.

The focus of the NRC-sponsored research in this area has been to provide additional data to support the technical basis for nondestructive evaluations, tube integrity, and consequential tube rupture (CSGTR). The research builds on extensive previous research and will support technical evaluations of licensee submissions and inspections of steam generator tubes. The results of this program will be documented in several NUREGs or technical letter reports. These reports will include the following:

1. "Consequential SGTR Analysis for Westinghouse and Combustion Engineering Plants with Thermally-Treated Alloy 600 and 690 Steam Generator Tubes"
2. "Algorithms to Automatically Analyze Eddy Current Data"
3. "Creep and Leak Rate Models for Alloy 690 Steam Generator Tubes"

4. "Stability of Circumferential Flaws in Once-through Steam Generator Tubes Under Thermal Loading during LOCA, MSLB, and FWLB"
5. "Leak Rates and Burst Pressures for Flaws in the U-bend Region of Steam Generator Tubes"
6. "Assessment of Eddy Current Methods to Detect and Size Flaws in the U-bend Region of Steam Generator Tubes"
7. "Development and Validation of Models for Predicting Leakage from Degraded Tube-to-Tubesheet Joints during Severe Accidents"
8. "Evaluation of Examination Guidelines for Pulled Steam Generator Tubes"

Assessment: The current industry inspection and integrity models have been confirmed by the NRC-sponsored research. Moreover, there is now a very large database to support analysis of licensee submittals. Alloy 690 tubed steam generators are exhibiting excellent behavior and the inspection programs have been in place for over 20 years. Thus, while the current programs are expected to produce valuable insight, there is little justification for further NRC-sponsored research in this area with the exception of special cases that may arise in the future.

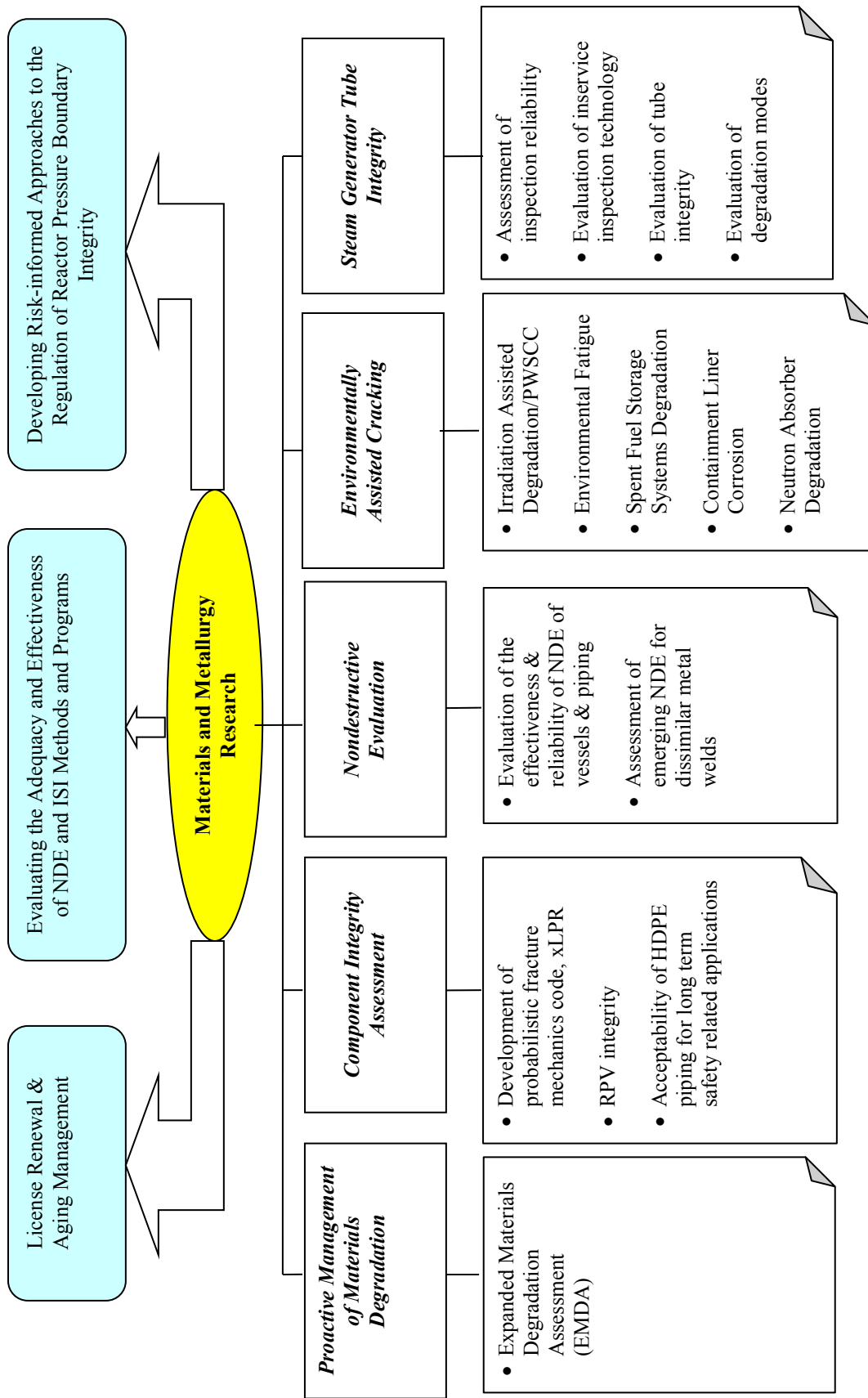

Figure 4. Current NRC Research Activities in Materials and Metallurgy

10. NEUTRONICS AND CRITICALITY SAFETY

Background

The technical capability to conduct neutronics and criticality evaluations in concert with state-of-the-art computational analysis tools is an essential core competency of the U.S. Nuclear Regulatory Commission (NRC). This capability connects with numerous research and regulatory activities within the agency and thereby continues to be of particularly high importance. Specific areas that define the focus of these research activities in neutronics and criticality safety include:

- Fission reactor neutronics analyses which include moderator, coolant, and fuel types for current and advanced designs and configurations and address steady-state and transient conditions,
- Nuclide generation and depletion computations to evaluate reactor and spent nuclear fuel decay heat powers, radioactive source behaviors, and radionuclide inventories,
- Radiation transport and attenuation applied to material damage, dosimetry, activation, and shielding evaluations for radiation protection, and
- Nuclear criticality safety, preventing and mitigating critical configurations outside reactors, for a variety of applications.

Important categories of recent and future direct application activities are:

- Confirmatory analyses for licensing reviews of operating light-water reactor extended power uprate applications, including licensing approval of advanced modes of operation for boiling-water reactors (BWRs),

- Burnup credit methodology development for spent nuclear fuel criticality analysis for pressurized-water reactor fuel,

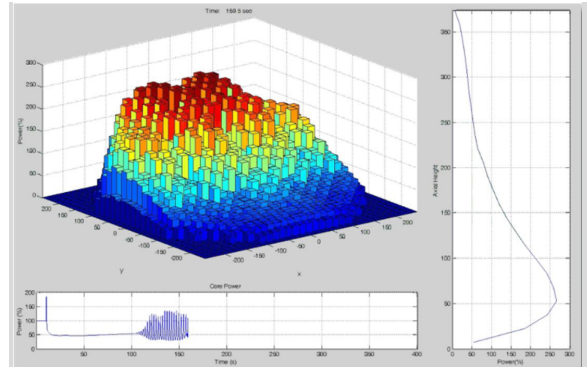

Power oscillation visualization during simulated ATWS with instability

TRACE/PARCS methodology is being used to simulate complex transients such as anticipated transients without SCRAM with instability (ATWS-I). Visualization tools have been developed to analyze and display the evolution of the power oscillations during ATWS-I and to study the oscillation contour.

- Certification of new light-water reactor (LWR) core designs and confirmation of applicant accident analyses, especially for integral advanced reactors and small modular reactors, and
- Spent fuel criticality analysis methodologies for advanced and long term fuel storage analysis for spent fuel pools and canisters.

Related Office of Nuclear Regulatory Research (RES) programs supported and monitored by this research area include the fuel cycle oversight process, fuel rod mechanical and thermal analysis, and high burnup fuel performance and safety evaluations. An important component of this RES work is continuing training

programs for agency staff on the use of these computer codes and application methods for performing licensing analysis and related review work.

The primary computational resources available to the staff for neutronics and criticality analysis include the SCALE suite of computer codes maintained in cooperation with the U.S. Department of Energy (DOE) through Oak Ridge National Laboratory (ORNL). The Purdue Advanced Reactor Core Simulator (PARCS) code provides three-dimensional core depletion and reactor kinetics that can be used in conjunction with the TRACE (TRAC/RELAP Advanced Computational Engine) computer code for thermal-hydraulics analyses.

Current Research Activities

The research programs are defined and supported by user needs within the agency and/or by NRC obligations under the Energy Policy Act. The program plans are well-developed and documented appropriately. Specialized areas of particular importance at this time in the areas of reactor performance analysis, methods development, training programs, and analysis methodology support are listed below:

- Evaluate recent analyses applications using TRACE/PARCS to support staff evaluations of the Maximum Extended Load Line Limit Analysis Plus (MELLLA+) protocol for extended power uprates in BWRs for near term improvement opportunities in analysis protocol, code capability enhancement, and benchmarking requirements.
- Maintain the PARCS code package and expand training of NRC staff in use of the code and its limitations. Provide user support for the PARCS code package for use in analysis of LWR designs.

- Augment the recently completed pressurized-water reactor (PWR) spent nuclear fuel burnup credit methodology and applications to develop the regulatory basis for burnup credit for BWR fuel in spent fuel pools, dry storage canisters, and transport systems. This work is a long term research program element and includes:
 - Determining reactivity influences due to variations in input parameters for BWR burnup credit criticality safety evaluations.
 - Supporting isotopic analyses validation (SCALE/TRITON depletion calculations) with available measured isotopic composition data.
 - Evaluating available critical experimental data to support BWR fuel critical evaluations.
- As was done within the PWR burnup credit analysis and application methods research program, develop a logical and consistent approach to identification and treatment of uncertainties in the analysis for BWRs.
- Provide continued support for the development and use of benchmark data for validation of burnup credit criticality analyses, including the MINERVE database from France that is part of the Organization for Economic Cooperation and Development/Nuclear Energy Agency (OECD/NEA) Burnup Credit Benchmark Exercise. Identify any additional improvement opportunities from this work for the PWR analysis program and assure program application to the BWR methods development and analyses requirements. Focus should include technical basis development and support for expanded guidance on burnup credit in spent nuclear fuel storage and transport applications.

- Develop a user guide and deliver staff training for the application of SCALE/TRITON in the generation of cross section libraries for the PARCS code.
- Upgrade the SCALE code package capabilities in the areas of in-core power peaking, reactor stability and control, core monitoring, fuel burnup, radionuclide inventories for accident source terms, safe shutdown, decay heat power, radiation sources and attenuation, and nuclear criticality safety. Modify SCALE architecture to enable parallel processing in analysis of accident sequences.

Lower Priority Research Activities (related to NGNP, MOX, and advanced fuel cycles)

As with other research areas, some of the program elements have been slowed or deferred as a result of resource redirection due to Fukushima response activities. The following activities have been affected based upon programmatic and priority changes since the 2012 ACRS (Advisory Committee on Reactor Safeguards) review and evaluation of the program:

- Develop nuclear data libraries for Next Generation Nuclear Plant (NGNP) designs for use in the SCALE code. Investigate reactor neutronics for the prismatic and pebble-bed designs for NGNP. Enhance computational capabilities to enable prediction of nuclide composition, decay heat, criticality and associated uncertainties for gas reactor fuel at burnup of 80 and 160 gigawatt days per metric ton (GWd/t). Enhance radiation transport methods and databases to assess shielding and evaluate irradiation degradation of the structural integrity of graphite and metal components in NGNP.

- Perform criticality analyses to support licensing of the Savannah River mixed oxide (MOX) fuel fabrication facility.
- Investigate criticality issues of fuel with greater than 5 percent enrichment in uranium-235 (²³⁵U).

Assessment and Recommendations

The prioritization to achieve progress on key research areas in this program is appropriate and should be effective to achieve the most important research progress and results. Accordingly, we agree with those elements deferred as described above.

Expanded application capability, improved accuracy, and computational efficiency demands on neutronics and criticality analyses should be achieved in both near term and long term research programs. Licensees of existing and planned reactors continue to optimize core designs using improved analytical techniques, some of which require full core, coupled approaches to safety analyses. Current analyses and related regulatory issues continue to demonstrate the need for additional uncertainty and sensitivity analyses to improve understanding and regulatory interpretations of the analysis results. In addition similar capabilities must be applied to assure appropriate safety analyses for integral small modular and large advanced reactors.

As a prime example the TRACE/PARCS analyses used to evaluate BWR performance in complex ATWS transients initiating from the MELLLA+ operating regime demonstrate the value of advanced methodology and high quality modeling application. The analysis methodology and visualization techniques (displayed in the insert figure) elevate the capability of the RES staff to better compare and evaluate results, identify and explain sensitivities, and communicate findings with applicants and licensees.

The burnup credit methodology developed for PWRs to improve isotopic composition analyses and criticality predictions represents a key success. The importance of developing a logical and consistent approach to evaluate appropriate uncertainties was recognized and an effective program and methodology was devised.

A similar quality approach designed to develop analysis methods and their technical bases for BWR applications is being implemented. The staff has identified the objectives that are critical to the success of this program. This work should also continue to incorporate and support international benchmark validation derived within the OECD/NEA MINERVE program. Further, the staff has ongoing plans to modify and extend the existing NRC codes and methods to accommodate new spent fuel pool, spent fuel canister, and core configurations, including those for current and advanced light water reactors as well as small modular reactors.

11. OPERATIONAL EXPERIENCE

Background

Operational experience (OpE) data can provide an important source of information which can be used to refine and improve the effectiveness of the regulatory process. Since passage of the National Energy Policy Act in 1977, the U.S. Nuclear Regulatory Commission (NRC) has explicit responsibility to collect and analyze OpE data. The NRC decided at that time to use data from a voluntary industry program; initially the Nuclear Plant Reliability Data System, and currently known as the Institute of Nuclear Power Operations (INPO) Consolidated Events System (ICES).

Data are also obtained from Licensee Event Reports (LERs) submitted directly to the NRC.

With the increased use of risk insights to inform the regulatory process, OpE data, when properly documented and analyzed, are important to assure the risk insights have an adequate basis for use in decisionmaking.

Finally, OpE data provide a measure of regulatory effectiveness and input to the required annual report to Congress on significant operating events.

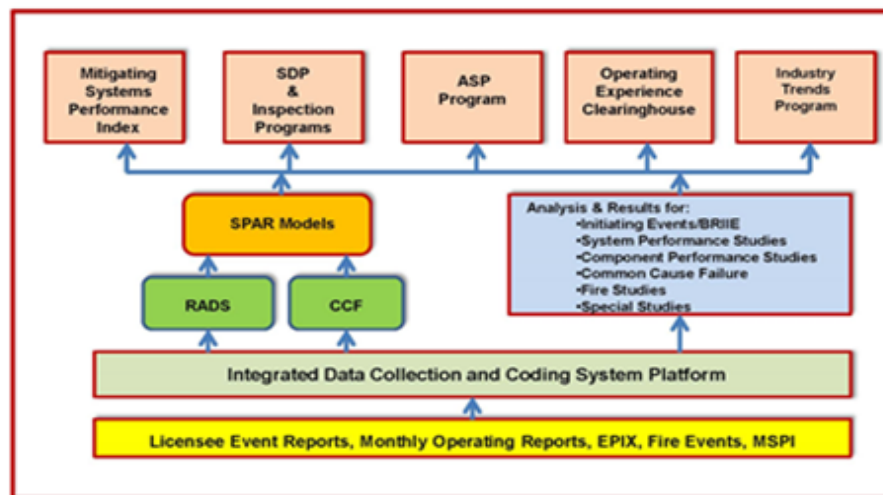

Sources and uses of operating data and analyses in NRC regulatory programs

Current Research Activities

The Office of Nuclear Regulatory Research (RES) Data Collection, Analysis and Trending Program (Program) interfaces are shown on page 58 (Figure 5). The program is ongoing, and it evolves as required to meet changing needs. An important user of program output is the Accident Sequence Precursor Program that results in an annual SECY which addresses: (1) the evaluation of precursor data trends and (2) the ongoing development of associated risk models. Other users include the Reactor Oversight Program and Industry Trends Program. Data analysis and summarization are currently performed by Idaho National Laboratory. The Program process and results are well displayed on numerous NRC Web site pages, so that much of the information is made widely available both within and outside the NRC. A few of the topics on the current Reactor OpE Results and Databases page include the following as examples:

- Fire Protection
- Fitness-for-Duty Programs
- Multiple/Repetitive Degraded Cornerstone Program
- Buried Piping Activities
- Loss of Offsite Power
- Industry Performance of Relief Valves
- Common-Cause Failure Insights

In its 2012 report to the Commission on the review and evaluation of the NRC Safety Research Program, the Advisory Committee

on Reactor Safeguards (ACRS) emphasized the importance of OpE data to the enhancement of planning for the operational response to an emergency event. This work is ongoing in support of Near-Term Task Force (NTTF) Recommendation 8. The Human Factors Information System (HFIS) provides a limited OpE data reference concerning human performance.

Assessment and Recommendations

The primary sources of operating experience data are the INPO's EPIX (Equipment Performance and Information Exchange System), LERs, and inspection reports. These sources provide information on operational failures. When these data are used to support risk analysis, they must be augmented with estimates of the successes (all demands, both successes and failures, must be considered, i.e., data are needed on the number of demands and times of operation). The demands are highly plant-specific, involving operating practices, the details of testing (e.g., exactly which portion of the equipment is tested), and details of the surveillance procedures (e.g., a pump test often requires operation of a number of associated valves generating additional demands on those valves).

Many plant-specific probabilistic risk assessments (PRAs) have documented thorough success and failure data and the NRC's Handbook of Parameter Estimation for Probabilistic Risk Assessment (NUREG/CR-6823) provides guidance on this process. Lacking accurate plant-specific success data, it must be recognized that there is substantially greater uncertainty in the count of successes compared to the count of failures. Likewise,

any generic industrywide failure rate data should include substantial uncertainty due to plant-to-plant variability in the number of successes.

Some years ago, the former Office for Analysis and Evaluation of Operational Data (AEOD) published a number of reports (NUREG/CR-5500, Volumes 1-11) that

investigated this issue and provided industrywide failure rate estimates for a variety of equipment. RES should examine the impact of the uncertainty in success data in their applications and analyses. Expanding the previous work of AEOD with research to fully incorporate these uncertainties may be appropriate.

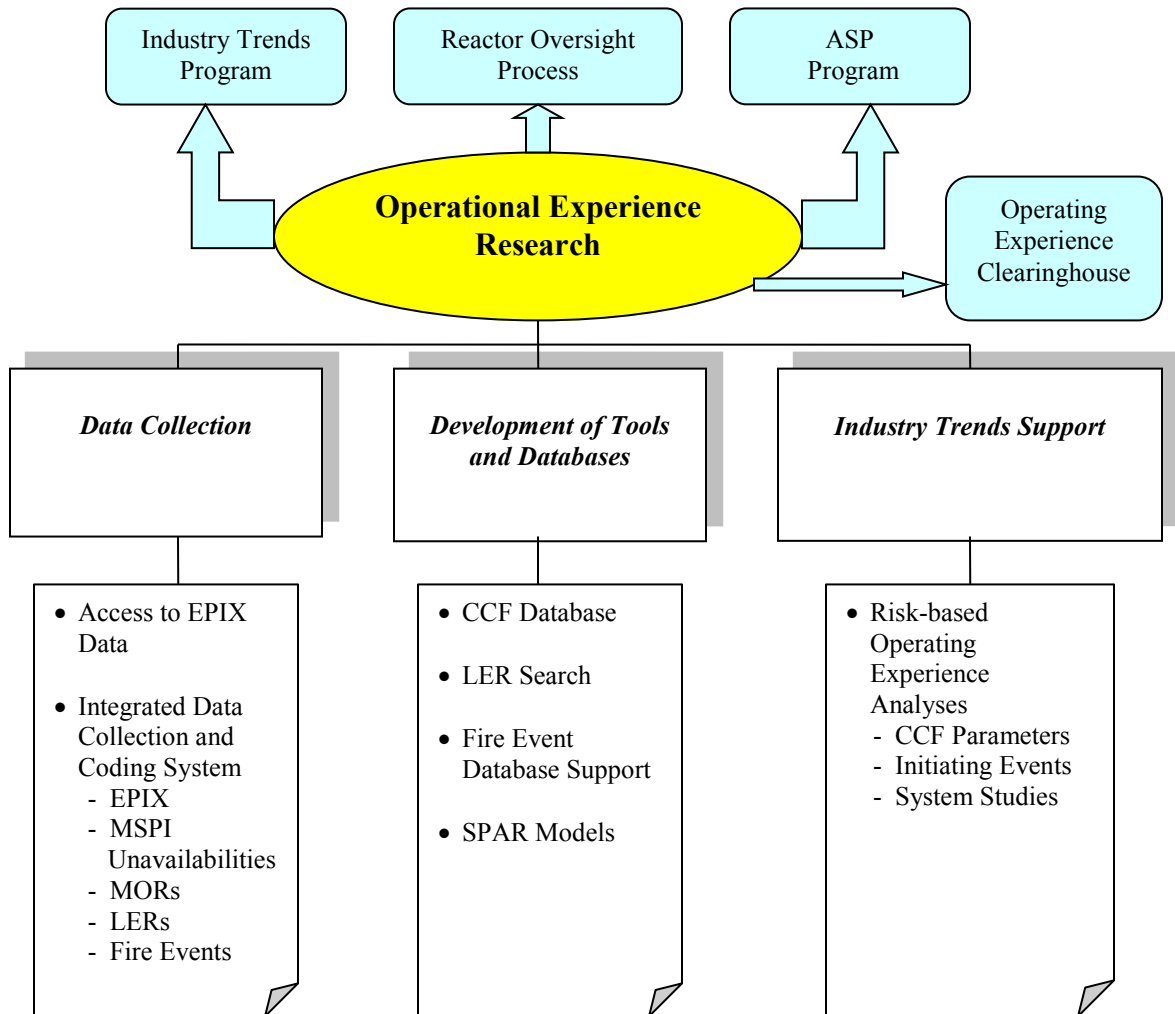

Figure 5. Current NRC Research Activities in Operational Experience

12. PROBABILISTIC RISK ASSESSMENT

Background

Probabilistic risk assessment (PRA) is an essential technology for the U.S. Nuclear Regulatory Commission (NRC). The use of risk information in the regulatory process for operating reactors is well-established. PRAs are being used to inform design decisions for new reactors and will be used in future regulatory oversight of those designs. Risk significance evaluations for emergent issues provide an important perspective to inform NRC policies, priorities, and regulatory decisions. The proposed transition to a more fully integrated risk management regulatory framework will increase reliance on risk information throughout all elements of NRC decisionmaking. The NRC must have state-of-the-art PRA capabilities to support these regulatory functions.

In its 2012 report to the Commission on the review and evaluation of the NRC Safety Research Program (NUREG-1635, Vol. 10), the Advisory Committee on Reactor Safeguards (ACRS) noted that much of the recent research work in this area has focused on applications of existing PRA models and data to support the reactor oversight process for the current reactor fleet. Extensions of PRA scope and the development of new methods have not been priorities. That emphasis continues to guide much of the current PRA research and planned activities. Technical issues and challenges identified during the development of a full-scope Level 3 PRA for a multi-unit operating reactor site will provide an important stimulus and focus for needed extensions of risk assessment methods and modeling practices.

Current Research Activities

The Division of Risk Analysis of the Office of Nuclear Regulatory Research (RES) has adopted a goal-oriented framework to organize its research programs. The four fundamental program goals are:

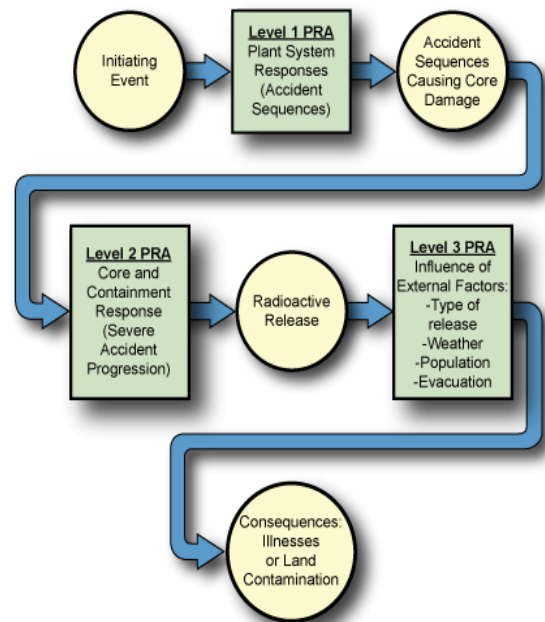

- (1) Support the Reactor Oversight and Operating Experience Programs
- (2) Remove obstacles to implementation of risk-informed regulation
- (3) Expand PRA infrastructure to encompass new and advanced reactor concepts and designs
- (4) Support continuous advancement in PRA state-of-the-art and state-of-practice

The ACRS has noted that this type of framework “could provide a basis for developing long-term research goals that can provide a constant vision of where the PRA research program should be headed.” The ACRS continues to encourage that broad perspective and an emphasis on future research needs.

The Division of Risk Analysis of RES has developed close working relationships with its counterparts in the Office of Nuclear Reactor Regulation (NRR) and the Office of New Reactors (NRO) to define specific user needs and priorities for short-, intermediate-, and long-term research projects. Memoranda of understanding with organizations such as the National Aeronautics and Space Administration (NASA) and Electric Power Research Institute (EPRI) have been used effectively to share knowledge and resources. Cooperative research agreements and grants with universities provide an important channel for the development of advanced analysis methods. The ACRS supports these efforts and encourages further collaboration for mutual benefits in areas of focused technical needs.

Figure 6 shows the program goals and lists the current research topics in each area. The following items briefly summarize selected research projects that extend the scope of current NRC-supported risk models and analysis methods.

SPAR Models Extension and Support

Standardized Plant Analysis Risk All Hazards Models (SPAR-AHZ): Limited models for external initiating events have been developed for 20 plants. This total includes four more plants since the 2012 ACRS review of this program. The models for 17 plants are based primarily on information derived from the Individual Plant Examination of External Events (IPEEE) analyses. The models for three plants (D.C. Cook, Shearon Harris, and Vogtle) are more comprehensive. They have been validated

by comparisons with more recent plant-specific information and design features, including internal fire analyses that have been performed for transition to National Fire Protection Association (NFPA)-805 at D.C. Cook and Shearon Harris. A project is underway to validate the SPAR-AHZ models and create new models for other plants.

Low Power and Shutdown (LPSD) Models: The current scope of the SPAR models includes shutdown operating states for only eight plants. No extension of the SPAR modeling effort for shutdown modes has occurred since the 2012 ACRS review of this program.

Level 2 Models: Limited-scope Level 2 PRA models have been developed for Peach Bottom Unit 2, Sequoyah, and Surry Unit 2. These models include an evaluation of severe accident progression and containment functions to support the quantification of large early release frequencies. The Peach Bottom Level 1 and Level 2 models have been linked through the SAPHIRE software to develop an integrated capability model for that plant.

Digital I&C PRA

The digital Loop Operating Control System (LOCS) for the Advanced Test Reactor (ATR) at the Idaho National Laboratory is being used as an example system to focus two quantitative software reliability research activities.

A Bayesian Belief Network (BBN) methodology has been proposed to facilitate quantitative evaluation of software reliability. The methodology develops causal relationships between quality attributes of the software development process and reliability of the product software. The results of the BBN provide a prior estimate for the software failure rate, including an evaluation of the uncertainty. If testing or operational data are available, a Bayesian update of the prior can be performed to

produce a posterior distribution for the software reliability.

Statistical testing of the Loop Operating Control System (LOCS) software will provide quantitative measures of the software reliability to perform its intended functions in the context of the success criteria and boundary conditions that apply in the pilot model. The test data may be used directly to quantify software failure modes, or the data may be used to update the BBN estimates.

Support for Fukushima Near-Term Task Force Initiatives

Two research projects support resolution of issues that were identified in the Fukushima Near-Term Task Force (NTTF) report (SECY 11-0093) and subsequent Commission guidance.

RES is supporting the development of policies and guidance for an integrated regulatory framework that implements the risk-informed, performance-based, defense-in-depth principles that are proposed by the NTTF (Recommendation 1) and the Risk Management Task Force (NUREG-2150).

In accordance with NTTF Recommendation 3, a project is underway to perform a feasibility study for evaluating the risk from seismically-induced fires and floods.

SPAR Models for New Reactor Designs

This project supports the development of SPAR models for each certified new reactor design. Models for internal events that occur during full power operation have been completed for the AP1000, US-APWR (advanced pressurized-water reactor), US EPR (evolutionary power reactor), and both versions of the advanced boiling-water reactor (ABWR) (GE and Toshiba). A SPAR model has not yet been developed for the economic simplified boiling-water

reactor (ESBWR) design. The AP1000 models have been extended to include seismic events, fires, and internal flooding. Efforts are currently focused on development of a shutdown model for the AP1000.

Support for Advanced Light Water Reactor Reviews

Current research activities for advanced reactor designs are limited to the development of guidance for the technical adequacy of PRAs that will be performed to support design-specific licensing reviews for small modular reactors. A pilot study to apply the risk-informed licensing framework proposed in NUREG-1860, "Feasibility Study for a Risk-Informed and Performance-Based Regulatory Structure for Future Plant Licensing, Volumes 1 and 2," for a specific advanced reactor design has been cancelled.

Level 3 PRA Project

This project involves the development of a full-scope comprehensive Level 3 PRA for an operating plant site. The PRA scope covers all plant operating modes, spent fuel storage pools, and onsite dry cask storage facilities. The analyses will include internal and external hazards. Site-level risk from accidents that involve multiple radiological sources will also be evaluated (i.e., the reactor units, spent fuel pools, and dry storage casks).

The project is benefitting substantially from voluntary support by Southern Nuclear Operating Company and an existing memorandum of understanding with EPRI. The PRA is being performed for Vogtle Electric Generating Plant Units 1 and 2. Available plant-specific models and data are being used as a basis for development of full-scope NRC models. EPRI is providing additional input and reviews through its participation in the project Technical Advisory Group.

This project is a major research effort. It accounts for a considerable reorganization of PRA research priorities since the 2012 ACRS review of this program. The project will advance the state of knowledge about plant-level and site-level risk beyond the landmark NUREG-1150 study, “Severe Accident Risks: An Assessment for Five U.S. Nuclear Power Plants,” performed more than 20 years ago. It will also integrate substantial advancements in understanding and modeling of internal hazards, external hazards, severe accident phenomena, containment performance, and offsite consequences. The project intends to use current state-of-the-practice methods and modeling techniques, with limited extension to new research. However, this project will identify needs for future research efforts to refine the treatment (i.e., reduce the uncertainty) of issues that are currently evaluated with rudimentary models or excessively conservative assumptions.

Assessment and Recommendations

The program structure in Figure 6 facilitates examination of the fundamental goals of each project and the balance among research priorities. For example, the PRA research program managers indicated that approximately 40 percent of all resources are currently allocated to projects in support of goal (1), approximately 30 percent are allocated to goal (2), approximately 5 percent are allocated to goal (3), and approximately 25 percent are allocated to goal (4)². These allocations are more balanced among the four fundamental research goals than was the case when the 2012 ACRS review was conducted.

The current programs under goal (1) are influenced primarily by a strong RES emphasis on responsiveness to immediate user needs and short-term requirements to

support existing PRA model infrastructure for the Reactor Oversight Process. Maintenance and updating of SPAR models, extension of those models to include a consistent level of detail for each operating reactor, comparisons with industry PRA models, and compilation of operating experience data are important tasks to support risk-informed decisionmaking and balanced reactor oversight. Those support activities for existing SPAR models do not typically require extension of fundamental analytical knowledge, methods, or modeling techniques beyond the current capabilities of trained PRA practitioners.

In its 2012 review of this program area, the ACRS recommended that RES should examine the feasibility for increased sharing of SPAR model maintenance and support activities among the regional offices, headquarters staff, and contractors, with increased technical responsibilities allocated to risk engineers in the regional offices. The ACRS continues to encourage that diversification of PRA knowledge and modeling capabilities, allowing RES to focus more effectively on advancement of state-of-the-art risk assessment methods and practices.

The current programs under goal (2) address a variety of intermediate- to long-term research needs. Resources are allocated about equally between the development of methods and modeling capabilities for focused issues (e.g., digital instrumentation and control (I&C) systems and software, seismically-induced fires and floods) and support for broader regulatory initiatives (e.g., a Risk Management Regulatory Framework, PRA standards and technical guidance). The framework in Figure 6 provides a structure for examining the overall goals and direction of the PRA research program. Therefore, for a clear understanding of RES priorities, it is important to assign specific projects to the most appropriate category. There is a conceptual overlap between some of the projects in this area and the objectives for

² These estimates are very approximate. They are noted here only to illustrate broad relative allocations for the purposes of this report.

goal (4). For example, the projects for evaluating digital I&C systems and seismically-induced fires and floods may be more appropriately associated with extension of current state-of-the-practice methods and modeling techniques. The ACRS supports those projects and agrees that they are important for improved understanding of these difficult issues. However, the ACRS recommends the original intent of each element in the goal-oriented framework should be examined carefully to ensure that the distribution of projects and resources accurately reflects the overarching RES priorities.

The current programs under goal (3) have been influenced very significantly by the compound effects from limited RES resources and a slowdown in the development and certification of new reactor designs. These pragmatic considerations have affected several near-term research priorities. Cancellation of the planned pilot study of a risk-informed licensing framework for advanced reactors may be an ill-advised decision. Performance of early pilot studies for proposed methods and regulatory practices provides valuable experience and feedback to focus research for necessary refinements. Small modular reactor designs that include several units at a single site with common external infrastructure introduce additional regulatory challenges that must be addressed to understand and manage the risk from potential single-unit, multiple-unit, and site-level accidents. Analytical capabilities, modeling techniques, and regulatory tools to support a risk-informed licensing process for those reactors must be developed and tested well in advance of the first applications. The ACRS recommends that RES should pursue a pilot study to apply the risk-informed licensing framework proposed in NUREG-1860 for a specific new small modular reactor design. The study should address site-level issues that affect accident progression, mitigation options, emergency planning, and offsite consequences. It

should be coordinated with the availability of information about the selected reactor design and with evolving activities to support development of an integrated Risk Management Regulatory Framework.

Almost all of the programs under goal (4) support development of the Level 3 PRA. The ACRS continues its strong support for this project. It will provide an integrated risk model context to define the scope and requirements for additional intermediate- and long-term research. Some of the difficult technical issues are known and are being addressed by current projects, but at a relatively low level of effort. Other specific challenges will emerge as the Level 3 PRA models are assembled and analysts discover inevitable unexpected problems. Consistent assessment of the site-specific risks from internal and external hazards; accidents that affect stored spent fuel; events that occur during plant shutdown; and integration of the Level 1, Level 2, and Level 3 PRA models will also address issues that have been identified in the wake of the accidents at the Fukushima Dai-ichi site. The ACRS recommends that RES should use evolving knowledge and insights from the Level 3 PRA project to risk-inform initiatives for specific research that may be proposed as a direct consequence of NRC and industry responses to the Fukushima Dai-ichi accidents.

RES has completed an important update to NUREG-1855, "Guidance on the Treatment of Uncertainties Associated with PRAs in Risk-Informed Decision Making," which contains practical guidance on methods to systematically identify, document, and quantify sources of uncertainty. However, a disciplined assessment of uncertainty is not yet applied consistently throughout the agency. The ACRS recommends that RES should initiate efforts to ensure that an appropriate characterization of uncertainty is performed in all agency analyses. Explicit acknowledgement, quantification, and communication of uncertainties will be a key

element for rational understanding of public health risk and its contributors as PRA results are expanded to integrate the risks from hazards such as fires, floods, seismic events, and other extreme natural phenomena. A clear understanding of the uncertainties and their sources is also essential for risk-informed regulatory decisionmaking and rational selection among possible risk management options.

Substantial efforts have been made to improve security against physical and cyber attacks on our operating nuclear power plants. New plants will further integrate security protections from the initial stages of their designs. Despite these efforts, concerns remain that the applied security controls may not be allocated optimally to cope with the full spectrum of potential threats. The ACRS recommends that the fundamental risk assessment framework and analysis techniques should be applied to address these concerns and to assess proposed protection strategies for future evolving threats. An integrated risk assessment process can also provide a perspective that more fully addresses issues that affect both reactor safety and physical security. RES should initiate a research project and pilot applications to examine the use of risk assessment methods to inform security programs and practices.

The ACRS encourages active collaboration among RES, other Government agencies, industry research organizations such as

EPRI, and universities to effectively share knowledge and experience that contribute to intermediate- and long-term research objectives. These collaborative programs are often the first to suffer in times of declining resources. Although modern risk assessment is generally characterized as a “mature” science, further research is needed to develop practical methods, models, and data for realistic evaluation of several difficult issues. Collaborative programs and tailored research projects should remain an integral part of the RES initiatives to address these issues.

During 2013, decisions were made to permanently shut down four U.S. reactors. Others may follow over the next few years. These actions raise questions about whether the NRC has fully addressed the risks from decommissioning activities. The Nation continues to debate options for disposal of used nuclear fuel and high level wastes. Recently proposed revisions to Title 10 of the *Code of Federal Regulations* (10 CFR) Part 61, “Licensing Requirements for Land Disposal of Radioactive Waste,” have focused attention on the scope of performance assessments for sites that provide long-term storage of low level wastes. The ACRS recommends that RES should initiate a project to examine how quantitative risk information can be used to inform regulatory decisions in these interrelated disciplines. These activities do not align directly with research programs that are intended to support operating reactors, new reactors, or advancement of risk assessment methods. Therefore, RES support for reactor decommissioning and waste disposal activities may represent a fifth goal in the general framework of Figure 6.

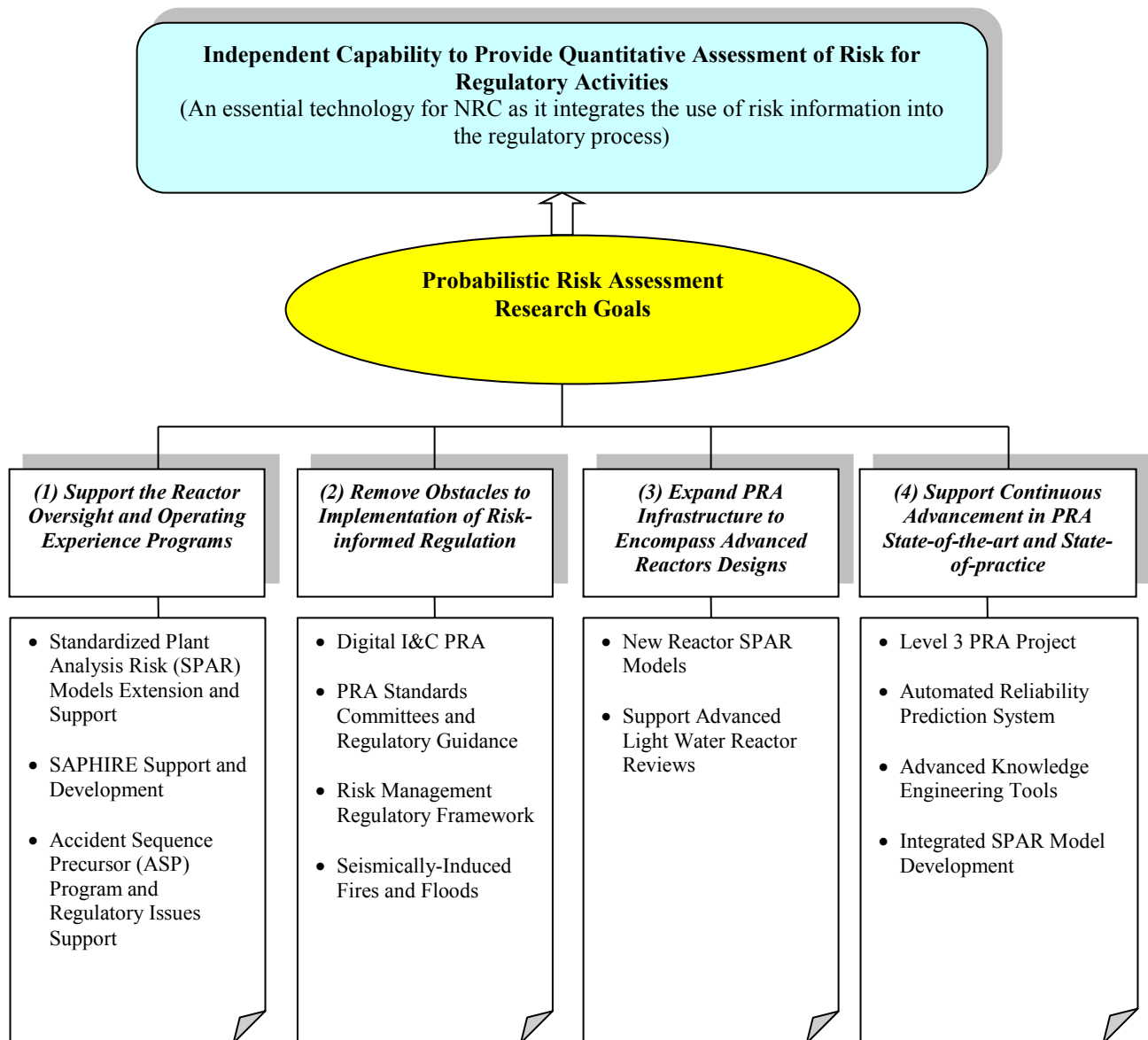

Figure 6. Current NRC Research Activities in PRA

13. RADIATION PROTECTION

Background

The U.S. Nuclear Regulatory Commission (NRC) continues to maintain a program of research related to radiation protection in the areas of:

- risks from radiation
- the sciences of internal and external dosimetry
- the fate and transport of radioactive materials in the human body and in the environment

A major thrust of this research is to collect, analyze, and disseminate information on occupational exposures reported to NRC by licensees. This information is used to track the effectiveness of licensees' As Low As Reasonably Achievable (ALARA) programs and will form the basis for future studies to evaluate the health effects of this group of workers. Another important thrust is to develop and maintain tools for assessments related to licensing, siting, environmental performance, and the decontamination and decommissioning of licensed facilities. Additionally, the NRC continues to participate in international standards setting efforts to exchange technical information to the benefit of all participating organizations.

Current Research Activities

The current NRC research activities in the area of Radiation Protection are depicted in Figure 7. The research is focused on development and maintenance of health effect/dose calculation tools, emerging health effects and dosimetry research, and participation in a number of national and international collaborative radiation protection activities. There are also some efforts on preparation of exposure and abnormal occurrence reports. These are all

essential activities and need to be sustained.



Biokinetic Model

RES is working closely with other Federal agencies to support and monitor the work of Oak Ridge National Laboratory (ORNL) on development of biokinetic and dosimetric models and dose coefficients for occupational and public exposure to radionuclides that are based on International Commission on Radiological Protection (ICRP) Publication 103 recommendations.

DEVELOPMENT AND MAINTENANCE OF HEALTH EFFECTS/DOSE CALCULATION TOOLS

VARSKIN: The NRC sponsored the development of the VARSKIN code in the 1980s to assist licensees in demonstrating that they have approved radiation protection programs that include established protocols for calculating and documenting the dose attributable to radioactive contamination of the skin. Since that time, the code has been significantly enhanced by adding the

ability to model three dimensional sources (cylinders, spheres, and slabs) with materials placed between the source and skin (including air gaps that attenuate the beta particles). In addition, the code incorporated a user interface that greatly simplified data entry and increased efficiency in calculating skin dose.

Since the release of VARSKIN 3 in 2004, the NRC staff has compared its dose calculations for various energies and at various skin depths, with doses calculated by the Monte Carlo N-Particle Transport Code System (MCNP) developed by Los Alamos National Laboratory (LANL). That comparison indicated that VARSKIN 3 overestimated the dose with increasing photon energy. RES recently completed further enhancement of the code, including replacement for the code's photon dose algorithm.

The current version of the VARSKIN code does not accurately predict beta dose from some radionuclides for some exposure conditions. The accuracy of the code decreases with skin depth. In order to address these issues, RES is currently sponsoring a research project to replace the current beta dose model in order to enable the code to more accurately model beta dosimetry resulting from contamination on the skin or on protective clothing covering the skin. The secondary objective of this project is to further enhance the code's functionality. RES also plans to develop a training module for using the code.

Radiological Toolbox: The NRC developed the radiological toolbox as a means to quickly access databases needed for radiation protection, shielding, and dosimetry calculations. The toolbox is essentially an electronic handbook with limited computational capabilities beyond those of unit conversion. The toolbox contains radioactive decay data; biokinetic data; internal and external dose coefficients; elemental composition of a large number of materials; radiation interaction coefficients;

kerma coefficients; and other tabular data of interest to the health physicist, radiological engineer, and others working in fields involving radiation. The toolbox includes a means to export the tabular data to an Excel worksheet for use in further calculations. It operates in a Windows 7 environment.

RADTRAD 4.0: The RADionuclide Transport and Removal And Dose Estimation (RADTRAD) code uses a combination of tables and numerical models, based on simplified source term parameters, to determine the time-dependent dose at user-specified locations for a given accident scenario. It also provides the inventory, decay chain, and dose conversion factor tables needed for the dose calculation. The RADTRAD code can be used to assess occupational radiation exposures (typically in the control room); to estimate site boundary doses; and to estimate dose attenuation due to modification of a facility or accident sequence. RADTRAD was rewritten in 2009 as a plug-in to the Symbolic Nuclear Analysis Package (SNAP). SNAP removes the need for analysts to use the text-based entry methods by providing a powerful, flexible, and easy-to-use graphical user interface (GUI).

RES is currently sponsoring a research project to add more features to the RADTRAD plug-in to SNAP before the final release of RADTRAD 4.0. This project will also provide support for development of the combined RADTRAD 4.0 user manual, theory manual, and verification & validation (V&V) documentation as a NUREG/CR report.

REIRS: The REIRS database is a comprehensive system used to compile and analyze occupational radiation exposure reports, which licensees submit on an annual basis as required by 10 CFR 20.2206, "Reports of Individual Monitoring." This information is used to produce the annual publication NUREG-0713, "Occupational Radiation

Exposure at Commercial Nuclear Power Reactors and Other Facilities.”

RES is currently sponsoring a research project on expanding the current REIRS database to include additional NRC and Agreement State licensee information and conducting analyses of international occupational radiation exposure databases.

PARTICIPATION IN NATIONAL AND INTERNATIONAL RADIATION PROTECTION ACTIVITIES

RES is actively engaged in monitoring and participating in a number of national and international committees (e.g., the National Council on Radiation Protection and Measurements, the National Academy of Sciences, the International Commission on Radiological Protection, and the NEA Committee on Radiation and Public Health). NRC research is also well leveraged by working with a number of collaborating agencies, including the U.S. Environmental Protection Agency. Such activities promote consistency and coherence in regulatory applications of radiation protection and health effects research among NRC programs, as well as those of other Federal and State regulatory agencies.

EMERGING HEALTH EFFECTS AND DOSIMETRY RESEARCH

Radiation Worker Health Studies: The NRC has entered into an interagency agreement with the U.S. Department of Energy’s (DOE’s) Office of Science in a Low Dose Radiation Research Program to study the health effects of more than 1 million radiation and atomic veterans. The One Million U.S. Radiation Worker study is designed to provide information on risk following low dose rate exposures. The significance of this research is considerable because it applies directly to existing concerns about and standards for chronic radiation exposure. The collaborating or cooperating agencies include DOE, U.S. Department of Defense, U.S. Department of

Veteran Affairs, National Cancer Institute, and National Aeronautics and Space Administration.

Research began on the nuclear power worker cohorts in fall 2012. The NRC expects to see the results in late 2014. The results of this study will provide valuable information for future radiation protection standards-setting bodies and any resultant occupational radiation dose standards.

Analysis of Cancer Risks in Populations Living Near NRC-Licensed Nuclear Facilities: Efforts are underway to have the U.S. National Academy of Sciences conduct a study analyzing the cancer risk of populations living near NRC-licensed facilities, including power reactors and fuel cycle facilities (e.g., fuel enrichment and fabrication plants). This study will update and expand on the 1990 U.S. National Cancer Institute report, “Cancer in Populations Living near Nuclear Facilities.” The staff plans to use this report as a scientifically defensible resource to aid in addressing continued stakeholder concerns about perceived elevated cancer rates in populations near reactors, including cancer incidence (i.e., being diagnosed with cancer but not necessarily dying from the disease).

The NRC and NAS agreed on a two-phase approach: (1) preparation of a scoping study to determine the best methodology, the best approach, and the potential limitations for performing the cancer incidence and mortality epidemiology study and (2) conduct of the actual study.

The NAS Phase 1 committee completed their report in May 2012 and recommended two alternative approaches for assessing cancer risks. The committee also recommended a pilot study of seven nuclear facilities to assess whether the approaches could work on a larger scale. The NRC has engaged with the NAS to perform the Phase 1 recommendations and expects the pilot studies to be completed in 2015.

Assessment and Recommendations

The staff has developed an appropriate and robust research program in the areas of radiation protection noted above. This program includes radiation protection of workers and the public and radiological assessments related to radiation exposure and health risks around NRC-licensed nuclear facilities.

The ACRS is supportive of RES's participation in national and international efforts relating to radiation protection. These collaborations provide excellent opportunities for the NRC staff to benefit from the work of other organizations in the United States and around the world.

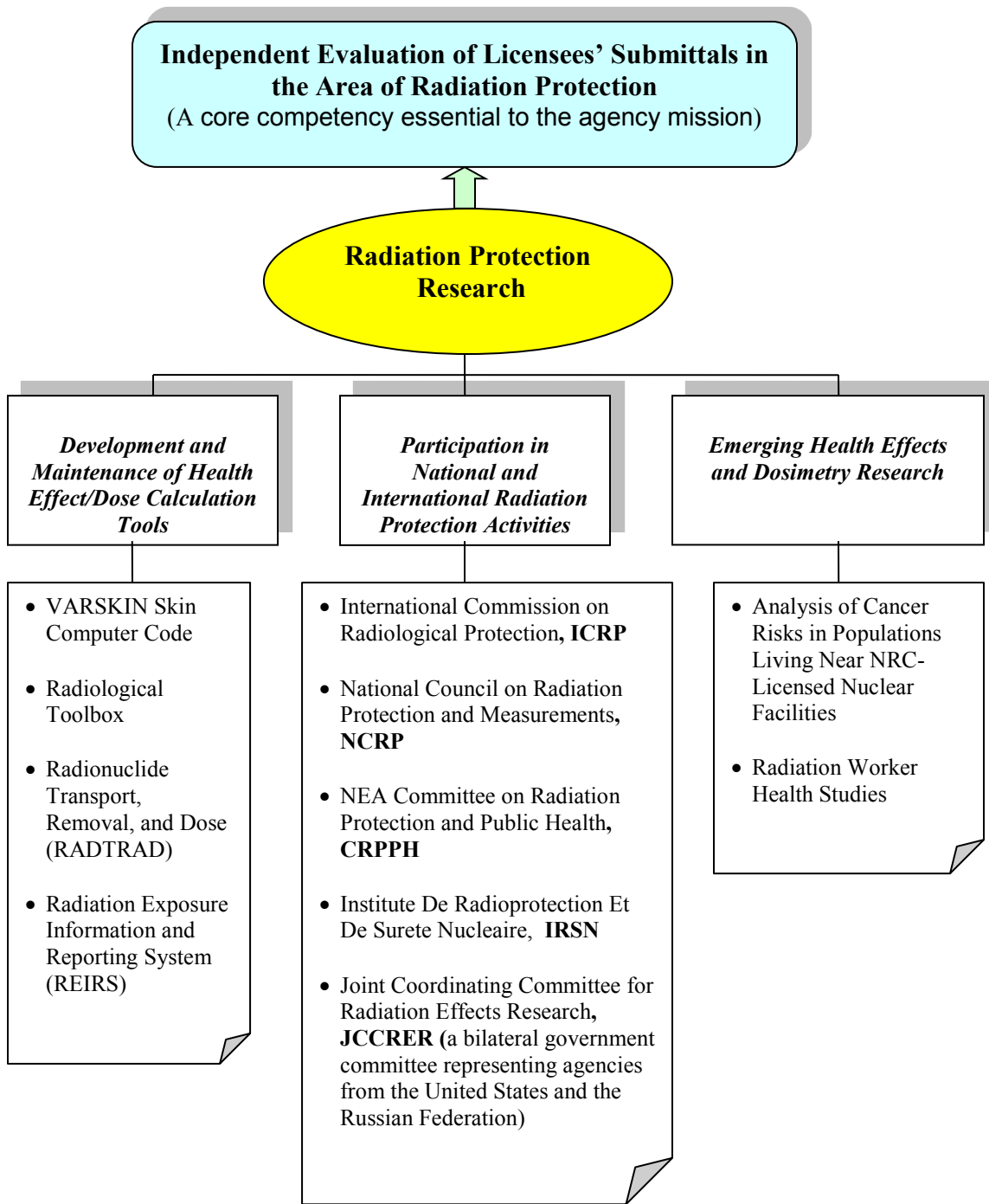

Figure 7. Current NRC Research Activities in Radiation Protection

14. NUCLEAR MATERIALS AND WASTE

Background

The NRC continues to maintain a program of research related to nuclear materials and radioactive waste topics associated with licensing, facility siting, facility environmental performance, and the decontamination and decommissioning of licensed facilities.

Current Research Activities

Research activities in the general areas of nuclear materials and waste reflect the current hiatus in the resolution of policy issues. By in large, the current activities address issues encountered or anticipated in the inspection and monitoring activities. Among such current activities are:

Stress Corrosion Cracking Analysis of Dry Cask Storage Materials: Evidence of dust deposition on surfaces of dry cask storage containers has been found. In locations near coasts the deposited material includes chlorides that could sustain stress corrosion cracking of the cask material should they hydrate in humid environments. The research attempts to discover the stress corrosion cracking potential of these deposits.

Spent Fuel Cask Thermal Testing Phase 2: The current efforts focus on the vulnerability of elastomeric materials used for sealing storage casks to sustained periods of modestly elevated temperatures. Results of this work could also be pertinent to issues of head seals for the Mark I and Mark II boiling-water reactors.

Analysis of Vacuum Drying of Spent Nuclear Fuel Storage Canisters: It is difficult to remove liquid water from interstitial locations throughout fuel assemblies and the like. Residual water in

storage casks will react with cladding on the fuel and other metals to form hydrogen that can further embrittle the fuel cladding. This research is directed at determining how vacuum drying can be better used to remove residual water from storage containers.

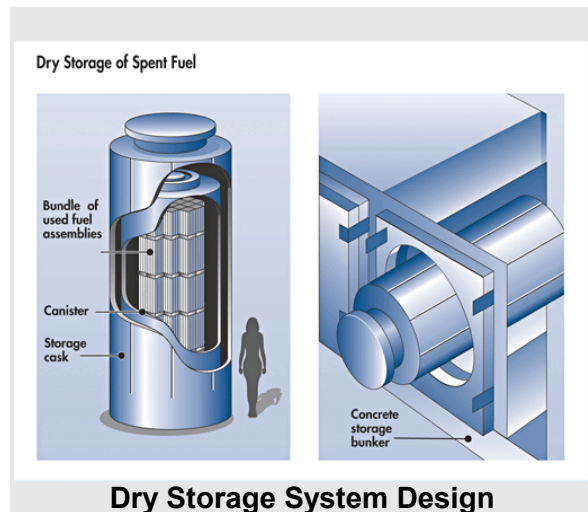

Hydride Reorientation Effects on Cladding Fracture: Zirconium alloy fuel cladding absorbs hydrogen during normal fuel operation. The absorbed hydrogen precipitates as zirconium hydrides when the fuel is cooled below normal fuel operating temperatures. The precipitated hydrides can affect the fracture properties of the cladding during storage.

Assessment and Recommendations

The research activities listed above have been prompted by current regulatory and monitoring efforts and appear to be useful expenditures of NRC resources.

Electrochemical separation has been suggested as a means to facilitate the safe disposal of waste. The NRC staff has a research program to better understand the

possible separations processes and hazards that could arise in the possible use of electrochemical preprocessing of waste for disposal. This is of necessity a very exploratory effort. It would be useful for the staff to have access to the ASPEN code for the exploration of flow sheet alternatives and associated hazards. Very detailed work in this area should await more definitive proposals from potential licensees.

15. SEISMIC AND STRUCTURAL ENGINEERING

Background

Nuclear power plants are designed to cope with large seismic events – up to at least the safe shutdown earthquake (SSE). Earthquakes of greater magnitude have the potential to damage the power plant and physical barriers to radionuclide release. Earthquake damage can be a common cause mechanism for the failure of systems to prevent accidents and systems to mitigate accidents – extending even to the final line of defense-in-depth of public evacuation and emergency planning.

The massive damage to the Fukushima Dai-ichi nuclear complex in Japan following a severe earthquake and tsunami in March 2011 has highlighted the importance of seismic and structural engineering to the safety of U.S. nuclear power plants. Less well known, but also significant, was a severe earthquake in 2007 at the Kashiwazaki-Kariwa plant in Japan. The latter event was even more severe in terms of ground acceleration at the plant site, although less damage to the plant occurred. In both instances, the earthquakes exceeded the maximum design basis earthquakes to which the plants were designed, thus calling into question the probabilistic seismic hazard assessments used to develop site specific seismic hazards at those plants. Research was already underway by the U.S. NRC, in conjunction with U.S. Geological Survey (USGS) and National Institute of Standards and Technology (NIST), to develop improved seismic hazard assessments at nuclear plants in the central and eastern United States (CEUS), and this work is enhanced and supplemented by the current NRC seismic and structural research plan. The seismic research is supplemented by research in the areas of improved tsunami modeling, integrated tsunami warning for U.S. coastlines, and evaluation of tsunami impact on new and existing power plants.

Structural Engineering research is also being performed in the areas of concrete and steel containment vessel design and degradation, irradiation effects on concrete, Alkali-Silica Reaction degradation of concrete structures, and modeling of transportation of spent nuclear fuel. The Office of Nuclear Regulatory Research (RES) is participating in several international cooperative efforts directed at review and assessment of the Fukushima and Kashiwazaki-Kariwa events and improved understanding of earthquake and tsunami hazards. These programs will support user needs in the Office of Nuclear Reactor Regulation (NRR), Office of New Reactors (NRO), and Office of Nuclear Material Safety and Safeguards (NMSS).

Current Research Activities

Tsunami Hazard

Several research projects are underway directed at better understanding and definition of the Tsunami Hazard at U.S. nuclear power plants. Under one such project, “Tsunami Hazard Modeling and Integrated Tsunami Warning for US Coastlines,” NRC staff will be trained in the use of existing National Oceanic and Atmospheric Administration (NOAA) tsunami warning and modeling tools. A second project, “Tsunami Landslide Source Probability and Potential Impact on New and Existing Power Plants,” will develop probabilistic methods to evaluate landslide-based tsunami sources. These projects together will support a new regulatory guide on tsunami hazard assessment. Finally, the staff will participate in an International Seismic Safety Centre Tsunami/Seismic Project that will provide a mechanism for sharing international experience on the impact of

flooding on nuclear power plants, including Fukushima.

Seismic Hazard Assessment

There are currently several projects underway to improve assessment of the Seismic Hazard at new and existing nuclear power plants. The development of a new seismic source characterization (SSC) model for the central and eastern United States (CEUS) has been completed through the joint sponsorship of the NRC, Department of Energy (DOE), and the Electric Power Research Institute (EPRI). The existing, validated PSHA (Probabilistic Seismic Hazard Analysis) software will be modified to add capability to perform seismic hazard calculations using the CEUS-SSC model and the EPRI ground motion relationships, and a related project will further refine and inform the uncertainties in these models. The NRC continues to sponsor the Next Attenuation

Relationship for the Central and Eastern North America (NGA-East) project. The new ground motion characterization (GMC) model resulting from this project will replace the EPRI GMC model currently used for new nuclear power plants in the CEUS. The NGA-East Project is being sponsored cooperatively by the NRC, DOE, EPRI, and USGS. This project is expected to end in 2015.

Other seismic research projects will study paleoliquefaction as an aid in predicting large, but rare, earthquakes in the CEUS region; evaluate current state of seismic monitoring in the CEUS, improve the staff's site response capability; develop a two-dimensional non-linear soil response analysis capability as well as a multidimensional soil constitutive model; and support reviews of Fukushima Near-Term Task Force (NTTF) 2.1 submittals.

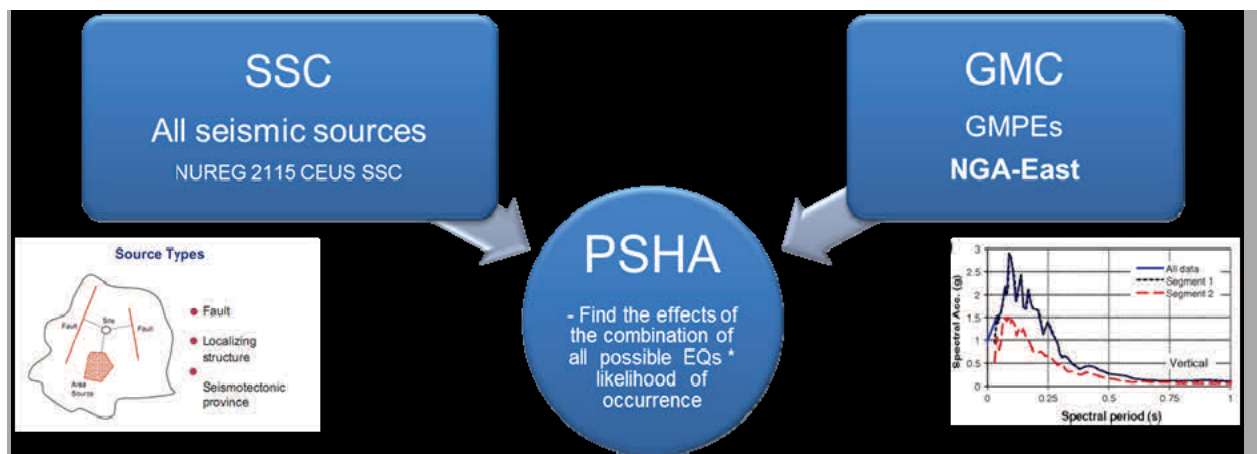

Seismic Hazard Assessment for the Central and Eastern United States

The NRC continues to sponsor projects in support of an updated assessment of seismic hazard in the central and eastern United States (CEUS). These projects will result in an advanced regional model for probabilistic seismic hazard analysis (PSHA) for critical facilities in CEUS

Geotechnical Seismic Engineering

Three research projects are underway (or have recently been completed) in the area of geotechnical seismic engineering. Recently completed projects include engineering evaluation of post-liquefaction residual strength, and an evaluation of the applicability of current structural, geotechnical, and seismic regulations to advanced design Small Modular Reactors on individual foundations. Projects currently underway include an evaluation of numerical tools for assessing soil-structure interaction (SSI) of deeply embedded nuclear power plant structures and a computational platform for addressing SSI under non-traditional seismic input loads.

Structural Seismic Engineering

Structural seismic engineering refers to analyzing the response of structures once the seismic ground motions are defined. NRC RES projects in this field include completion of a lessons learned report on the Kashiwazaki-Kariwa earthquake with specific emphasis on issues that may impact U.S. plants; analysis of two key issues identified in base-isolated structures; research in support of walkdowns of operating U.S. facilities for seismic and flood hazards; collaboration with the Japan Nuclear Engineering Society on seismic issues; and improvement of the staff's ability to estimate failure correlations for structures, systems, and components in seismic probabilistic risk analyses (PRAs).

Structural Engineering and Materials

Several instances of containment degradation have been observed in U.S. nuclear power plants. RES is pursuing several projects to provide better tools for addressing such degradation, which includes corrosion of steel liner or shell, loss of prestress, degradation due to repairs associated with steam generator replacement, and Alkali Silica Reaction (ASR) degradation of concrete structures.

Several new and ongoing research projects are directed at better understanding these mechanisms and modeling their effects on service life of the structures. In addition, research is underway to provide tools to better address new design concepts proposed for safety-related steel-concrete structures and the vulnerability of such structures to missile impacts and other threats.

Structural Analysis

Finally, research is underway to help maintain the NRC's state-of-art capability in nonlinear structural analysis to assess such topics as beyond-design-basis accidents and security threats. RES is participating in international cooperative research on impact testing, as well as analysis of drop tests of spent nuclear fuel transportation casks.

Assessment and Recommendations

The NRC seismic and structural research program in support of regulatory activities is being conducted under a well-developed research plan that has been broadly reviewed for both technical quality and programmatic elements. The program funds state-of-the-art work via contracts to several renowned organizations in the field, including national labs and universities, as well as international cooperative programs and collaborative research with other governmental agencies such as DOE. The ACRS believes that this program will adequately support the NRC staff's capabilities to evaluate potential risks to U.S. nuclear plants due to events such as the severe earthquakes and tsunami that impacted Japanese reactors and to assure the continued safety of new and operating U.S. nuclear power plants.

16. SEVERE ACCIDENTS AND SOURCE TERM

Background

The U.S. Nuclear Regulatory Commission (NRC) uses its severe accident expertise and analysis capabilities to support regulatory decisions for operating nuclear power plants and for certifying new and advanced reactor designs. Severe accident analysis tools also help the staff in its transition to a more risk-informed regulatory framework. In addition, severe accident analysis tools are used for better understanding of the progression and potential radiological releases due to such accidents.

The Office of Nuclear Regulatory Research (RES) long-term severe accident and containment response evaluation development plan focuses on two areas: maintenance and development of severe accident analysis tools and continued collaboration in international experimental research programs. The NRC made considerable investment to achieve the current levels of severe accident understanding. However, recent NRC investments have been limited to a level that only allows for continuation of required analysis and risk-informed activities.

Current Research Activities

Figure 8 illustrates current NRC severe accident and source term research activities. Current activities are focused on development and usage of the MELCOR code and other severe accident analysis tools and on participation in collaborative severe accident research programs. There are also some efforts underway on severe accident knowledge management.

The NRC leverages its resources by relying on international collaborative research

programs in the Pacific Rim (e.g., Japan and Korea) and Europe (e.g., France, Switzerland, and Germany). Knowledge gained from the NRC's past experimental work and from recent international experimental programs are systematically incorporated into MELCOR.

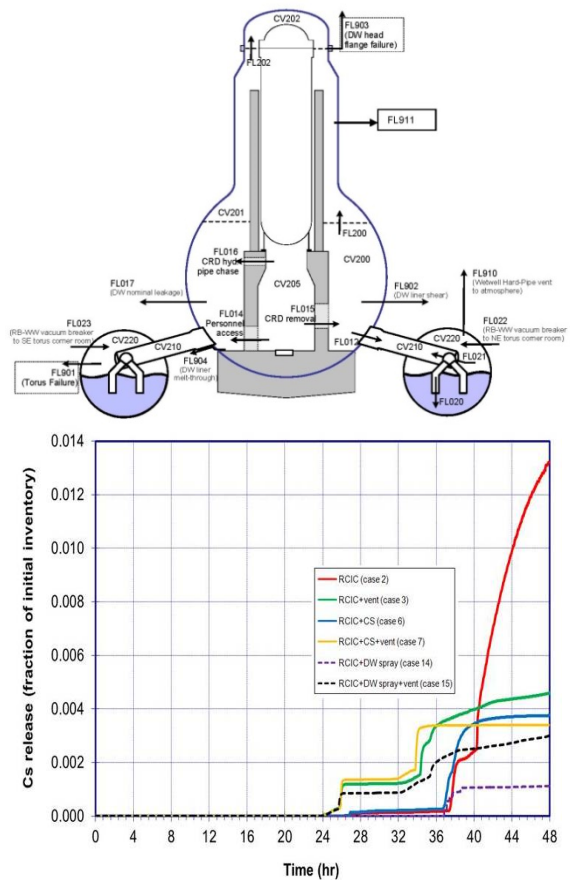

MELCOR Investigations of Effectiveness of Filtered Vents

In developing recommendations related to filtered containment venting, NRC completed MELCOR evaluations for a BWR Mark I plant to assess the effectiveness of filtered venting on cesium release for cases with various mitigating options, such as operation of Reactor Core Isolation Cooling System (RCIC), wetwell venting (vent), core sprays (CS), and Drywell sprays (DW spray).

Organized by the NRC, the international Cooperative Severe Accident Research Program (CSARP) is an annual forum for exchanging severe accident research findings. Twenty seven foreign countries currently participate in CSARP. One significant outcome of this effort is the adoption of the MELCOR code by most of the other countries and institutions as an analytical tool for severe accident analyses.

MELCOR Code Development and Usage

The MELCOR code is a fully integrated, engineering-level computer code whose primary purpose is to model accident progression in current nuclear power plants, new and advanced reactor designs, and some nonreactor systems such as spent fuel pools. Since the accident at Three Mile Island in 1979, significant advances have been made related to severe accident phenomena as a result of extensive domestic and international research. Updates to its models have allowed the MELCOR code to become the repository of this improved understanding. Efforts to enhance the Symbolic Nuclear Analysis Package (SNAP) plug-in for MELCOR have also continued, with improvements to streamline coupling between SNAP and MELCOR.

The MELCOR code, along with the MELCOR Accident Consequence Analysis Code (MACCS2) for modeling atmospheric dispersion and radiological consequence calculations, were extensively used in the State of the Art Reactor Consequence Assessment (SOARCA) project. Several recent modifications enhanced MELCOR capabilities for the SOARCA effort. These include (1) new default parameters, either as input records or sensitivity coefficients, that best capture experimental observations and improve code numerical robustness, (2) addition of a model to simulate the thermo-mechanical collapse of fuel rods with highly oxidized cladding at high temperatures, and (3) enhancement of the SPARC pool scrubbing model to treat fission product vapors. As part of the

SOARCA project, a draft of NUREG/CR-7008, "MELCOR Best Modeling Practices," has been developed to provide users guidance in selecting code options.

MELCOR and MACCS2 were used extensively to perform a large number of calculations in support of the response to the Fukushima Near-Term Task Force (NTTF) recommendation on containment vent filtration. It is anticipated that MELCOR calculations will also be used in support of implementing other NTTF recommendations.

The spent fuel pool (SFP) models in MELCOR have been developed over the past 10 years supported by experimental data. MELCOR was used in the zirconium fire experiments for boiling-water reactor (BWR) assemblies, and the predictions showed good agreement with data for the initiation and propagation of zirconium fire (NUREG/CR-7143, "Characterization of Thermal-Hydraulic and Ignition Phenomena in Prototypic, Full-Length Boiling Water Reactor Spent Fuel Pool Assemblies After a Postulated Complete Loss-of-Coolant Accident"). The code was also used for the recent Spent Fuel Pool Study (SFPS).

To support probabilistic risk assessment (PRA) and severe accident analyses for NRC design certifications, MELCOR analyses were performed for several new reactor designs (e.g., EPR (evolutionary power reactor), ABWR (advanced boiling-water reactor), ESBWR (economic simplified boiling-water reactor), US-APWR (advanced pressurized-water reactor), and AP1000). In addition to these new LWR (light-water reactor) designs, NRC will use MELCOR to provide confirmatory analysis of small modular reactors, including the iPWRs (integral pressurized-water reactors) that will be submitted to the NRC for licensing review. MELCOR models were developed for two iPWRs (e.g., the NuScale and mPower plants), and some preliminary severe accident simulations were completed

to support NRC reviews of iPWR design certifications.

MELCOR analysis also supports projects with the Division of Engineering and Division of Risk Analysis to estimate the risk from consequential steam generator tube ruptures in Combustion Engineering (CE) plants. The MELCOR model derives part of its input from FLUENT analyses. The output is combined with that from FLUENT to provide a time-dependent spatial distribution of temperature in the steam generator tubes for use in calculating failure. The MELCOR analyses also provide fission product release estimates. Efforts are underway to document results from this effort.

Various workshops and user training programs are conducted each year to support MELCOR users. For example, the MELCOR Code Assessment Program (MCAP) is an annual technical review meeting that focuses on MELCOR code development and assessment, providing a forum for users to present and discuss their experiences. In addition, several organizations conduct annual European MELCOR User Group (EMUG) meetings.

Collaborative Severe Accident Experimental and Analyses Research Programs

The NRC participates in several collaborative experimental severe accident research programs, which continue to provide key data for MELCOR model development and assessment. Table 1 summarizes the objectives and scope of current and recently completed international collaborative severe accident research programs. NRC participation in an international program is evaluated using established criteria to ensure that the expected value of such collaboration to the NRC is well worth the investment.

Data from these experimental collaborations have the potential to significantly impact severe accident assessments, including: the release of iodine, cesium, and

molybdenum based on PHÉBUS-FP and VERDON tests; containment iodine behavior in the PHÉBUS-FP, BIP2, and STEM-EPICUR tests; ruthenium release from fuel based on data from the VERDON and START tests; debris coolability based on data from the QUENCH-DEBRIS tests; melt spreading and core-concrete interaction phenomena based on results from the MACE and OECD-MCCI (Organization for Economic Cooperation and Development—molten core concrete interaction) tests; containment spray effectiveness based on results from several SARNET programs; and fuel-coolant interaction phenomena based on tests conducted in the FARO, KROTOS, and TROI facilities. MELCOR and other severe accident analysis code models have been revised to reflect these new results, and analyses completed with updated models provide essential input for decisions related to plant siting, equipment qualification, control room habitability, and emergency planning. For example, MELCOR models with updates to reflect recent findings from PHÉBUS-FP are currently being used to revise the Alternative Source Term.

In addition to collaborative experimental programs, NRC has and continues to participate in a number of international collaborative analytical activities. These include: (1) reactor applications of the fuel-coolant interaction tools under the OECD/NEA [Nuclear Energy Agency]-SERENA program; (2) benchmark exercise of core-concrete interaction codes against OECD/NEA-MCCI experiments at ANL; (3) OECD/NEA Benchmark Study of the Accident at the Fukushima Daiichi Nuclear Power Station (BSAF); (4) European Research on Containment thermal-hydraulics and Severe Accident Management (ERCOSAM); and (5) OECD/NEA Filtered Containment Venting Systems (FCVS) project. In addition, the NRC continues work-in-kind participation in the European Severe Accident Research NETwork of excellence (SARNET). Such efforts ensure that the NRC is cognizant of

analysis approaches taken by other international agencies and contribute to multinational convergence of evaluation methodologies and the success of the multi-national design evaluation program (MDEP). In addition, analysis activities help identify areas where further code enhancements may be warranted.

Severe Accident Research Knowledge Management

As a part of its commitment to the agency effort in knowledge management (KM), RES has initiated efforts to collect and catalogue experimental data and models used to describe severe accident phenomena for submittal to the NRC Agencywide Documents Access and Management System (ADAMS).

Over the years, the NRC invested heavily in severe accident research through major experimental and model development studies to achieve the current understanding of the progression and the radiological consequences of severe accidents. RES KM efforts are essential for preserving the information and insights gained from this research.

The NRC has also been participating in the SARNET2 project, which includes meetings and computer forums where different organizations can share their work and databases for preserving project information.

Assessment and Recommendations

The Advisory Committee on Reactor Safeguards (ACRS) continues to endorse the strategy that the NRC staff has developed to support regulatory decisions for severe accidents via computer code development validated by experimental data analysis and evaluation. This approach has successfully allowed the NRC to maintain and update its modeling capabilities for severe accident analyses.

The ACRS also continues to support the NRC approach to leverage resources by obtaining data through participation in international experimental collaborations. Planned program extensions and continuations of these collaborations are well worth the investment and essential for NRC to keep abreast of recent data affecting source term evaluations and analyses of the effects of proposed accident mitigation strategies. The ACRS plans to review the process used by the staff to determine that new data are sufficient to warrant improvement to severe accident analysis models.

The ACRS notes that models in the NRC's system-level code, MELCOR, were developed from a database that is primarily focused on in-vessel testing with significantly more PWR-specific experiments. Hence, it is anticipated that model deficiencies associated with BWR-specific phenomena, the impact of salt water addition, and ex-vessel phenomena will be identified as more information from the events in the Fukushima Dai-ichi nuclear complex in Japan become available. As such deficiencies are identified, ACRS recommends that the NRC expand its current severe accident research program to actively engage in efforts to obtain the required data to enhance and validate models that are found to be deficient.

The ACRS also endorses RES efforts to support agency KM efforts. The ACRS encourages RES to seek collaborations with other organizations, such as Electric Power Research Institute (EPRI), U.S. Department of Energy (DOE), and SARNET2, to leverage research funding to preserve and consolidate experimental data.

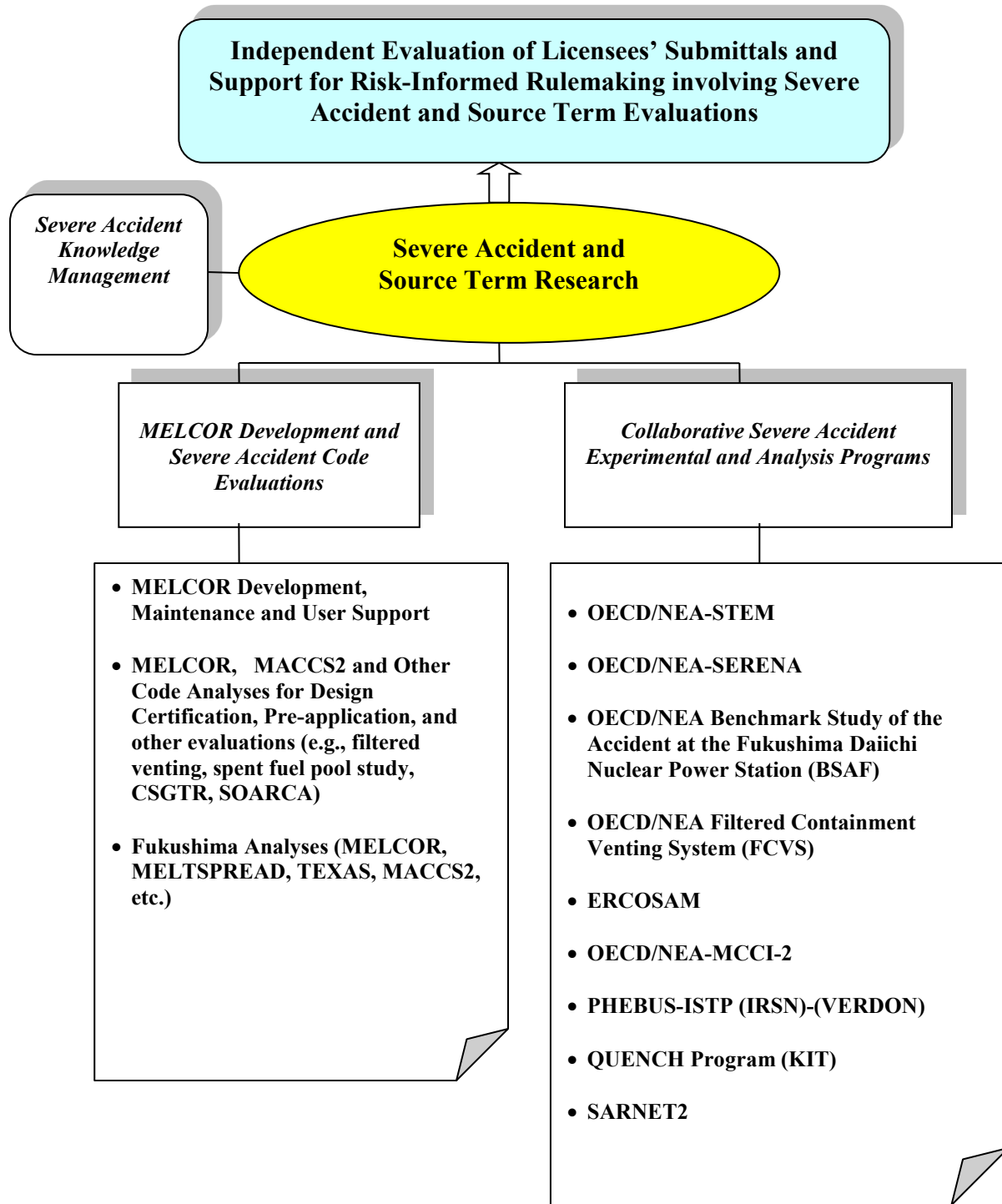

Figure 8. Current NRC Research Activities Related to Severe Accident and Source Term

Table1. International Collaborative Severe Accident Experimental Research Programs with NRC Participation

Program /Performing Organization (Country)	Objectives and Scope
OECD/NEA BIP2 (Behavior of Iodine Project), AECL (Canada)	BIP (completed) was initiated to provide separate effect tests and modeling studies of iodine behavior in a containment following a severe accident. The BIP-2 program is performing more detailed evaluations of iodine absorption on painted containment surfaces and organic iodine formation.
OECD/NEA-STEM (Source Term Evaluation and Mitigation) IRSN (France)	STEM was initiated to address remaining issues in source terms. The project focuses on iodine behavior under radiation in the EPICUR facility (aerosols, long term), on ruthenium chemistry in the primary circuit of a water cooled nuclear reactor and on the state-of-the-art on iodine interaction with paint. It involves two experimental projects: The Experimental Program for Iodine Chemistry Under Irradiation (EPICUR) and Study and Transport of Ruthenium in the primary circuit (START). EPICUR, a facility used under PHEBUS-ISTP that consists of a closed gas loop in which iodine samples can be irradiated, is being used to further study iodine release behavior from iodine loaded paint and from iodine aerosols. The START experiment consists of a controlled-temperature-profile heated tube in which different ruthenium species are introduced. The chemical form of deposits and transported species are observed.
OECD/NEA - SERENA (Steam Explosion Resolution for Nuclear Applications) KROTOS Experiments, CEA (France) TROI Experiments, KAERI (Korea)	<p>The SERENA program was established to assess the capabilities of fuel-coolant interaction (FCI) computer codes to predict steam explosion-induced loads in reactor situations. Phase II of the SERENA project is using the complementary features of the TROI (KAERI) and KROTOS (CEA) corium facilities. Experimental research is supplemented with analytical activities so as to improve the FCI codes and strengthen confidence in their applicability to severe accident scenarios.</p> <p>The SERENA program has been completed. OECD proposed a Technical Opinion Paper on the subject. One follow-on national program on corium-water interaction (ICE) is underway at IRSN. KAERI continues to perform additional experiments in the TROI facility. The NRC continues to follow these programs through bilateral agreements with the respective organizations.</p>
OECD/NEA- MCCI (Melt Coolability and Concrete Interaction) Project, ANL (United States)	<p>The focus of the original project, MCCI-I (completed), was to investigate the coolability of molten core materials, interacting with the containment structural concrete, by an overlaying water layer. The second phase of project (MCCI-II), carried out from 2006 to 2010, helped bridge data gaps not fully covered in previous tests. MCCI-II also addressed the effectiveness of design features in new LWR designs for augmenting coolability, e.g., CCI tests for examining the melt behavior with underlying cooled refractory basemat, similar to the EPR core retention concept.</p> <p>The NRC is participating in one joint EdF-IRSN/CEA-NRC test to confirm early water ingress phenomena. Data will be used in a benchmark effort by participants.</p>
OECD/NEA PHEBUS -FP and ISTP IRSN (France)	PHEBUS-FP Program (completed in 2006) consisted of a series of in-pile integral experiments of: fuel degradation; fission product release; radionuclide transport through a model of reactor coolant system; and aerosol behavior in model containment. The NRC also participated in the PHEBUS-ISTP follow-on program, which is made up of several separate effects projects to pursue specific aspects of PHEBUS-FP findings. With the exception of VERDON, all PHEBUS-ISTP experimental projects have been completed.
OECD/NEA Sandia Fuel Project (SFP) (United States)	This project provided experimental data relevant for hydraulic and ignition phenomena of prototypic LWR fuel assemblies. The proposed experiments focused on thermal-hydraulic and ignition phenomena in pressurized-water reactor (PWR) 17x17 assemblies and supplemented earlier results obtained for boiling-water reactor (BWR) assemblies. Code validations based on PWR and BWR experimental results considerably enhance severe accident code capabilities. This project to evaluate BWR experimental work has been completed, and results are documented in NUREG/CR-7143. MELCOR evaluations of PWR experiment results are underway.

17. THERMAL HYDRAULICS

BACKGROUND

Evaluation of thermal and hydraulic phenomena and their coupled effects on nuclear safety have always been central to the conduct of the NRC's regulatory mission. Of particular importance has been, and continues to be, the capability to independently confirm thermal-hydraulic analyses in submittals from licensees or applicants.

The thermal-hydraulic analyses are inherently complex because the phenomena are difficult to model, occur at large geometric scales, and usually result in strongly nonlinear behavior, which is difficult to model and solve. Early thermal-hydraulic approaches to analyses of nuclear power plants, therefore, adopted simple models to describe the phenomena with 'conservative' assumptions, to assure that large safety margins could be built into estimates of temperatures and pressure limits. With time, the experimental database and the confidence in the capability of more sophisticated models that better predict thermal-hydraulic behavior have grown. The NRC now evaluates license submittals from licensees employing such "best-estimate" thermal-hydraulic analyses together with estimates of uncertainties in predicting the limits. To reduce these uncertainties, analyses continue to grow ever more sophisticated partly enabled by computational capability, which continues to grow. This in turn allows for more detailed models that better portray the physical systems. It is necessary for the NRC to continue thermal-hydraulic development both to retain state-of-the-art capability and to keep pace with the sophistication of future submittals. Thus, the NRC, through its research program, maintains thermal-hydraulics competence and capability to conduct appropriate confirmatory analyses for safety evaluations.

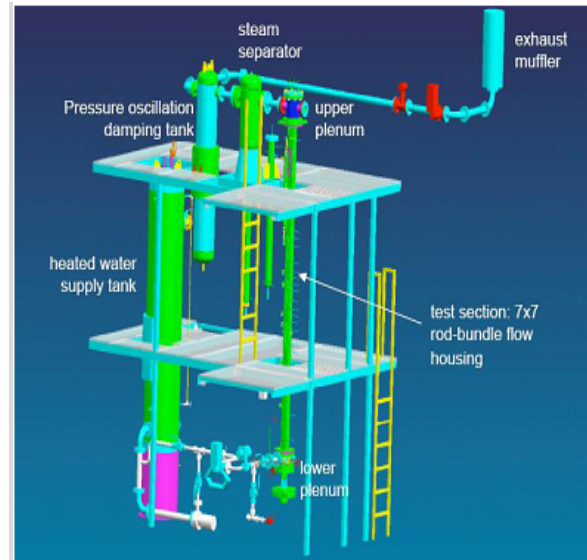

Rod Bundle Heat Transfer (RBHT) facility

Through the joint efforts of the United States Nuclear Regulatory Commission and Pennsylvania State University, an experimental Rod Bundle Heat Transfer (RBHT) facility was designed and built. The purpose of the facility is to collect fundamental rod bundle thermal-hydraulic data that can be used to develop and validate models for thermal-hydraulic codes used for safety analyses of nuclear power plants.

CURRENT RESEARCH ACTIVITIES

The organization of the main NRC research activities in thermal-hydraulics is depicted in Figure 9. The foci of the research activities are primarily on the development of the TRACE computer code for confirmatory analyses of a range of safety-significant thermal-hydraulic phenomena, and supporting experiments. There is also a modest effort to develop capability in multi-dimensional computational fluid dynamics (CFD), currently using commercial tools.

TRACE Computer Code Development and Validation

In the mid-1990s, a decision was made that the several primary reactor system thermal-hydraulic codes that were in use at that time be consolidated into a single code. The several codes included RELAP5 (for loss-of-coolant accident (LOCA)), TRAC-P (for PWR LOCA), TRAC-B (for BWR LOCA), and RAMONA (for BWR stability).

The models, correlations, and solution methodologies in these codes did not reflect the state-of-the-art and required in-depth modernization. It was also recognized that they had been designed at a time when computer capabilities were limited and included many structural features, such as memory management, that were no longer needed and increased the cost of continued code maintenance and development. The availability of graphical user interfaces and their wide acceptance also suggested the desirability of incorporating similar capability into the NRC codes. These considerations led to extensive code consolidation, model improvements, and implementation efforts, culminating in the development and validation of the TRACE computer code.

TRACE is meant to serve as the main tool for the confirmatory analyses of a broad range of thermal-hydraulic problems for current and new reactor designs. It has the potential to offer significantly enhanced capabilities for state-of-the-art analyses of thermal-hydraulic issues. Several important technical issues, such as core stability and Anticipated Transient without Scram (ATWS) behavior, involve coupling between neutronics and thermal hydraulics and require that TRACE be properly coupled to a neutronics code like PARCS, an activity that has been completed. The integration, validation, and assessment of the TRACE/PARCS coupled code has been recently completed so that it can be reliably used for confirmatory analyses. TRACE also has the capability to interface with the CONTAIN code for containment response

analysis as well as with other computational tools, including MATLAB.

Thermal-hydraulic system codes, including TRACE, solve an intertwined structure of approximate conservation equations and empirical correlations, which have become increasingly sophisticated. It is now common practice in many vendor analyses for the nuclear industry to employ at least three fields—droplets, continuous liquid, and continuous vapor—to capture core thermal-hydraulics behavior. The oil-gas industry already uses more sophisticated models such as the four-field description recommended by the peer-review group. All this has the potential to put the empirical correlations used on a firmer physical basis and reduce uncertainties.

Uncertainties and biases inevitably introduced by such empirical procedures need to be properly addressed. Because of these uncertainties, predictions of such codes are adequately accurate only within certain ranges of parameters. The codes cannot be given blanket approval for all situations to which they might be applied. In practice, a code, such as TRACE, must be qualified by assessment against a range of data that cover the phenomena that dominate the prediction of figures of merit, such as peak clad temperature, important to the regulatory process. These dominating phenomena change with the reactor systems and accident conditions being considered. In view of this, thermal-hydraulic codes need to be assessed for analyses of a specific accident in a particular system. Because of the high uncertainties that can exist in a calculation, modifications are being made to TRACE so that the code uncertainty can be quantified. The modifications are intended to be general, and enable the staff to evaluate uncertainty methods proposed by applicants as well as allow the staff to statistically determine the uncertainty in calculations made with TRACE and TRACE/PARCS.

RES has initiated a systematic assessment of the applicability of TRACE to analyze new reactor designs. Work on a detailed assessment of the applicability of TRACE to analyze ESBWR LOCAs, focusing on the collapsed liquid level in the reactor pressure vessel as the primary figure of merit, has already been completed. The assessment of the applicability of TRACE for confirmatory analyses of safety-significant thermal-hydraulic phenomena in the AP1000, APWR, and EPR designs has also been completed to validate the use of TRACE in the design certification process. Work is also ongoing to develop TRACE for applicability to iPWR designs such as NuScale and mPower. The pre-applicability assessments indicate that the TRACE and PARCS codes can be effectively used to perform thermal-hydraulic confirmatory analyses on iPWR designs.

In 1985, RES developed the International Code Assessment and Application Program (ICAP) to assess and improve its thermal-hydraulic computer codes. In the early 1990's, ICAP developed into the Code Application and Maintenance Program (CAMP). The CAMP agreement involves monetary and in-kind technical contributions. The technical contributions include sharing code experience and identifying areas for code and model development. The CAMP provides members with TRACE code. As TRACE matures, CAMP continues to be an important contributor to its assessment.

Experimental Studies of Thermal-hydraulic Phenomena

Thermal-hydraulic phenomena involved in normal and accident conditions for light-water reactors (LWRs) are complex, and often involve the difficult-to-model flow of two-phase mixtures (steam and water). Predictions from computer codes of such phenomena need extensive experimental validation, and there are many effects, such as those involving multidimensional two-phase flows in complex geometries,

where large-scale tests are the primary means of confirming the validity of these predictions. In view of this, NRC-RES has maintained two relatively large-scale experimental facilities:

- the PUMA facility at Purdue University for BWR-related issues
- the RBHT facility at Pennsylvania State University for PWR emergency core cooling issues

The Purdue University Multidimensional Integral Test Assembly (PUMA) is a medium-sized, reduced height scaled facility and has been used in the past to perform integral LOCA tests of interest for the ESBWR design. Tests have also been conducted at the PUMA facility to obtain experimental data on the void fraction distribution and fluid dynamics of a BWR suppression pool during the blowdown period. The results of these tests are used to support the technical assessment of Generic Safety Issue (GSI) 193, "BWR ECCS Suction Concerns."

The Rod Bundle Heat transfer (RBHT) facility at Pennsylvania State University (PSU) was developed to address issues related to emergency core cooling. The RBHT experimental program has been performing separate experiments using a full length rod bundle. The tests focus on steam cooling and reflood thermal-hydraulics, including the importance of spacer grids and droplet coalescence and breakup behavior in determining peak clad temperature (a key regulatory figure of merit). These results emphasize the need to move toward more detailed modeling of dispersed fields as recommended by the TRACE peer-review group.

An alternate approach to modeling dispersed and continuous fields explicitly is to develop so-called "closure relationships" for the evolution of interfacial area in two-phase flows. An exploratory program to this end has been going on at Purdue University to complement their experimental

program for some time. Tests have been performed with the emphasis of bubble interfacial area transport in pipes, annuli, and rod bundles. It is expected that when the data encompass the range of flow regimes expected in two-phase flows, then a model of interfacial area evolution will be developed for incorporation into the TRACE code, potentially improving its accuracy and reliability. An experimental research program at PSU is also in place to enhance the database for interfacial area models.

Development of interfacial area transport models may have some value as demanding research projects to educate the next generation of thermal-hydraulic experts. However, whether implementing such models in the TRACE code should be prioritized over development of the four-field model recommended by the TRACE peer-review group should be carefully assessed and reviewed. Since results from the interfacial area transport research have been slow in coming, the strategy for utilizing interfacial transport models in TRACE requires examination going forward.

In parallel to these efforts, the NRC is collaborating with international groups in undertaking experiments in facilities abroad, as noted below:

OECD/NEA ROSA-2: The NRC is participating in the OECD/NEA ROSA-2 Program to utilize the Large Scale Test Facility (LSTF) of ROSA (Rig-of-Safety Assessment) Program of JAEA (Japan Atomic Energy Agency) for studying the integral response of the core and steam generator. The full-height ROSA/LSTF integral test facility, with 1:48 volumetric scaling, is designed to investigate thermal hydraulic phenomena of interest to PWRs. The ROSA-2 Program was completed in 2012 and has provided both integral and separate-effects thermal-hydraulic data on intermediate break LOCA and on the recovery from Steam Generator Tube Rupture (SGTR) events. These data are being used to assess predictive capability of

thermal-hydraulic analysis codes including TRACE.

OECD/NEA-PKL-3: The OECD/NEA-PKL3 Program began in 2012 and is expected to conclude in 2015. The PKL facility is a full-height, 1:145 power and volume scaled replica of a 4-loop, 1300 MW PWR. The PKL-3 program has been developed to address new series of topics, to include beyond-design-basis accidents with significant core heatup, accident during shutdown conditions, and a followup to the boron-precipitation test conducted under PKL2. This program provides an extensive database for use in the further development and validation of thermal-hydraulic codes.

Development of Multidimensional CFD Capabilities

The NRC currently has a modest but productive effort in the area of computational fluid dynamics (CFD) using commercial CFD codes from ANSYS Inc. (FLUENT) and CD-Adapco (STAR-CCM+). These codes are user-friendly and are applied to a wide variety of industrial problems, with reasonably accurate results for steady-state single-phase flows or multiphase flows which are homogeneous and in equilibrium. In such applications, these commercial codes can provide three-dimensional single-phase or homogeneous equilibrium two-phase flow information not available from system code thermal hydraulic simulations. On the negative side, some of the code details cannot be readily subjected to peer-review because of commercial constraints. Nonetheless, their CFD predictions have been useful for multidimensional analyses of certain phenomena where such effects are significant, and have played a role in resolution of a number of broad technical issues, such as induced steam generator tube failures, distribution of injected boron in the ESBWR, spent fuel pool analyses, and predicting the scale-up behavior of advanced accumulators.

ASSESSMENT AND RECOMMENDATIONS

Excellent progress has been made in developing and incorporating the NRC's systems thermal-hydraulics code, TRACE, into the regulatory process. Further development should focus on implementation of the four-field thermal-hydraulics model, as recommended by the TRACE peer-review group. The research program on interfacial area transport should be phased out as the results are of limited value for TRACE applications.

The ACRS is supportive of the agency's active participation in international collaborative efforts, as they take advantage of facilities that are of a scale and capability that do not currently exist in the United States. They also draw on the expertise of international partners, who have continued to maintain a high level of capability in thermal-hydraulics. Complementary development of unique U.S. facilities to support confirmatory accident analyses for new fuel and reactor designs should be seriously considered. Integral tests would enhance confidence in regulatory analysis of new reactor designs. Such integral tests

cannot be carried out in any existing facilities.

The NRC currently has modest, but productive, efforts in the area of computational fluid dynamics (CFD) through the use of commercial CFD codes, which have played a role in improving the technical bases for certain licensing decisions. In this direction, licensees are and will continue to capitalize on the extraordinary advances in computing power and computational science to address many critical safety issues, e.g., prediction of the behavior of full-scale components, such as advanced accumulators, based on small-scale experiments. The agency should maintain independent confirmatory capabilities that keep pace with such developments in industry. To this end, the NRC should evaluate various options, which could include the following: First, participation and cost-sharing in programs with international partners to develop next-generation, high-fidelity, well-validated CFD simulation tools suitable for independent confirmatory analyses; Second, perhaps in conjunction with the first, formation of an NRC-US university consortium to develop such capability, leveraging the world-leading CFD expertise in several U.S. universities; Third, perhaps in conjunction the other options, building on one of the excellent open-source CFD platforms. While such platforms are still less user-friendly than commercial codes, they are being increasingly developed in this direction as they offer significant advantages in transparency, independent verification, and incorporation of advanced capabilities for transient multidimensional thermal-hydraulics computations.

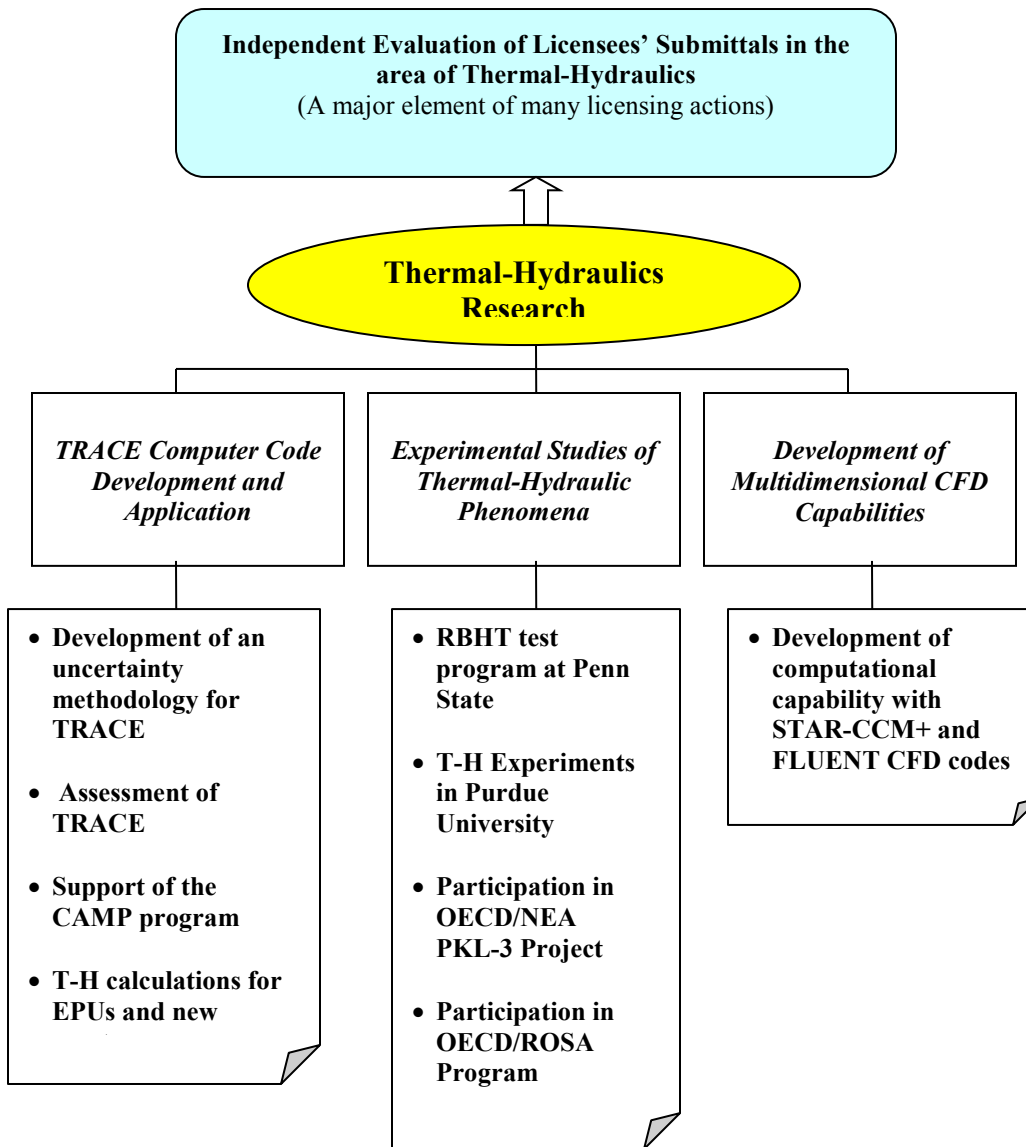

Figure 9. Current NRC Research Activities in Thermal-Hydraulics Research

18. REFERENCES

1. U.S. Nuclear Regulatory Commission, "Review and Evaluation of the Nuclear Regulatory Commission Safety Research Program," Advisory Committee on Reactor Safeguards (ACRS), NUREG-1635, Vol. 10, October 2012.
2. U.S. Nuclear Regulatory Commission, "Research Activities - FY 2012-FY 2014," NUREG-1925, Rev. 2, August 2013.
3. U.S. Nuclear Regulatory Commission, "Recommendations for Enhancing Reactor Safety in the 21st Century, The Near-Term Task Force Review of Insights from the Fukushima Dai-ichi Accident," July 12, 2011.
4. U.S. Nuclear Regulatory Commission, "Feasibility Study for a Risk-Informed and Performance-Based Regulatory Structure for Future Plant Licensing," NUREG-1860, Volumes 1 and 2, December 2007.
5. U.S. Nuclear Regulatory Commission, "Severe Accident Risks: An Assessment for Five U.S. Nuclear Power Plants," NUREG-1150, December 1990.
6. Public Law 109-58, "Energy Policy Act of 2005," enacted August 8, 2005.
7. U.S. Nuclear Regulatory Commission, "Verification and Validation of Selected Fire Models for Nuclear Power Plant Applications," NUREG-1824, Vols. 1-7, Electric Power Research Institute (EPRI) TR1011999, May 2007.
8. U.S. Nuclear Regulatory Commission, "A Phenomena Identification and Ranking Table (PIRT) Exercise for Nuclear Power Plant Fire Modeling Applications," NUREG/CR-6978, November 2008.
9. U.S. Nuclear Regulatory Commission, "EPRI/NRC-RES Fire PRA Methodology for Nuclear Power Facilities," NUREG/CR-6850, Vols. 1-2, EPRI TR 1011989, September 2005.
10. U.S. Nuclear Regulatory Commission, "Cable Response to Live Fire (CAROLFIRE)," NUREG/CR-6931, Vols. 1-3, April 2008.
11. U.S. Nuclear Regulatory Commission, "A Short History of Fire Safety Research Sponsored by the U.S. Nuclear Regulatory Commission, 1975-2008," NUREG/BR-0364, June 2009.
12. U.S. Nuclear Regulatory Commission, "Human Factors Considerations with Respect to Emerging Technology in Nuclear Power Plants," NUREG/CR-6947, October 2008.
13. U.S. Nuclear Regulatory Commission, "Expert Panel Report on Proactive Materials Degradation Assessment," NUREG/CR-6923, February 2007.
14. U.S. Nuclear Regulatory Commission, "Guidance on the Treatment of Uncertainties Associated with PRAs in Risk-Informed Decision Making," NUREG-1855, Draft Report for Comment - Revision 1, March 2013.
15. U.S. Nuclear Regulatory Commission, "Recommendations for Probabilistic Seismic Hazard Analysis: Guidance on Uncertainty and Use of Experts," NUREG/CR-6372, Volumes 1 and 2, April 1997.
16. U.S. Nuclear Regulatory Commission, "Nuclear Power Plant Fire Modeling

- Analysis Guidelines (NPP FIRE MAG),” NUREG-1934, EPRI 1023259, November 2012.
17. U.S. Nuclear Regulatory Commission, “Fire Dynamics Tools (FDT^s) – Quantitative Fire Hazard Analysis Methods for the U.S. Nuclear Regulatory Commission Fire Protection Inspection Program,” NUREG-1805, Supplement 1, Volumes 1 & 2, July 2013.
 18. U.S. Nuclear Regulatory Commission, “Cable Heat Release, Ignition, and Spread in Tray Installations During Fire (CHRISTIFIRE), Phase 1: Horizontal Trays,” NUREG/CR-7010, Volume 1, July 2012.
 19. U.S. Nuclear Regulatory Commission, “Cable Heat Release, Ignition, and Spread in Tray Installations During Fire (CHRISTIFIRE), Phase 2: Vertical Shafts and Corridors,” NUREG/CR-7010, Volume 2, December 2013.
 20. U.S. Nuclear Regulatory Commission, “Performance of Metal and Polymeric O-Ring Seals in Beyond-Design-Basis Temperature Excursions,” NUREG/CR-7115, April 2012.
 21. U.S. Nuclear Regulatory Commission, “Direct Current Electrical Shorting in Response to Exposure Fire (DESIREE-Fire),” NUREG/CR-7100, April 2012.
 22. U.S. Nuclear Regulatory Commission, “Joint Assessment of Cable Damage and Quantification of Effects from Fire (JACQUE-FIRE),” NUREG/CR-7150, Volume 1, October 2012.
 23. U.S. Nuclear Regulatory Commission, “EPRI/NRC-RES Fire Human Reliability Analysis Guidelines,” NUREG-1921, July 2012.
 24. U.S. Nuclear Regulatory Commission, “State-of-the-Art Reactor Consequence Analyses (SOARCA) Report,” NUREG-1935, November 2012.
 25. U.S. Nuclear Regulatory Commission, “A Proposed Risk Management Regulatory Framework,” NUREG-2150, April 2012.

BIBLIOGRAPHIC DATA SHEET

(See instructions on the reverse)

2. TITLE AND SUBTITLE

Review and Evaluation of the Nuclear Regulatory Commission Safety Research Program

3. DATE REPORT PUBLISHED

MONTH

YEAR

December

2014

4. FIN OR GRANT NUMBER

5. AUTHOR(S)

Advisory Committee on Reactor Safeguards

6. TYPE OF REPORT

Technical

7. PERIOD COVERED (Inclusive Dates)

8. PERFORMING ORGANIZATION - NAME AND ADDRESS (If NRC, provide Division, Office or Region, U. S. Nuclear Regulatory Commission, and mailing address; if contractor, provide name and mailing address.)

Advisory Committee on Reactor Safeguards
U.S. Nuclear Regulatory Commission
Washington, D.C. 20555-0001

9. SPONSORING ORGANIZATION - NAME AND ADDRESS (If NRC, type "Same as above", if contractor, provide NRC Division, Office or Region, U. S. Nuclear Regulatory Commission, and mailing address.)

Same as above.

10. SUPPLEMENTARY NOTES

11. ABSTRACT (200 words or less)

This report to the U.S. Nuclear Regulatory Commission (NRC) presents the observations and recommendations of the Advisory Committee on Reactor Safeguards (ACRS) concerning the NRC Safety Research Program being carried out by the Office of Nuclear Regulatory Research (RES). In its evaluation of the NRC research activities, the ACRS considered the programmatic justification for the research as well as the technical approaches and progress of the work. The evaluation identifies research crucial to the NRC mission.

12. KEY WORDS/DESCRIPTORS (List words or phrases that will assist researchers in locating the report.)

NRC Safety Research Program
Fukushima
Advanced Non-LWR Designs
Digital Instrumentation and Control Systems
Fire Safety
Reactor Fuel
Human Factors and Human Reliability
Materials and Metallurgy
Neutronics and Criticality Safety

Probabilistic Risk Assessment
Radiation Protection
Nuclear Materials and Waste
Seismic and Structural Engineering
Severe Accidents and Source Team
Thermal Hydraulics

13. AVAILABILITY STATEMENT

unlimited

14. SECURITY CLASSIFICATION

(This Page)

unclassified

(This Report)

unclassified

15. NUMBER OF PAGES

16. PRICE



Federal Recycling Program



**UNITED STATES
NUCLEAR REGULATORY COMMISSION**
WASHINGTON, DC 20555-0001

OFFICIAL BUSINESS



**NUREG-1635
Volume 11**

**Review and Evaluation of the Nuclear Regulatory
Commission Safety Research Program**

December 2014